

Klizno podizni sistem

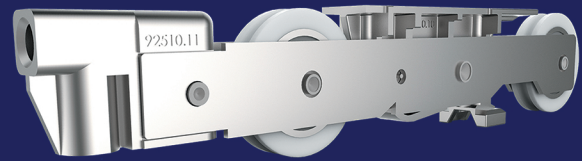

VABIS[®]

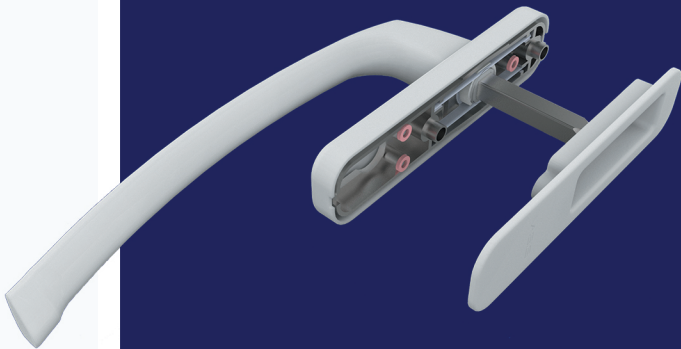

Katalog proizvoda
2016



O VABIS-u . . .



VABIS D.O.O. Aleksinac je nastao 1987 godine u Aleksincu, kao mala zanatska radionica, čija je hronologija razvoja sledeća:

- 1992 godine počinje da se bavi proizvodnjom okretnog okova za vrata i prozore,
- 1995 godine počinje da osvaja proizvodnju okretno-nagibnog okova za drvo,
- 2000 godine počinje sa osvajanjem i proizvodnjom okretno nagibnog okova za PVC profle,
- 2007 godine počinje osvajanje, a krajem godine i proizvodnju okova za Aluminijske prozore novije generacije,
- 2008 godine dobija TUV-NORD certifikat za sistem menadžmenta na osnovu EN ISO 9001:2000.
- 2011 Resertifikacija sistema kvaliteta i dobijanje sertifikata EN ISO 9001:2008.
- 2011 Dobija atest za okov prema EN 12400 i EN 13115 u renomiranom institutu if ROSENHEIM
- 2015 Dobija atest za okov prema EN 13126-16 u renomiranom institutu if ROSENHEIM.

VABIS D.O.O. je danas jedno ozbiljno preduzeće koje upošljava ukupno preko 80 radnika, od kojih jedan broj radi neposredno u VABIS-U a ostali su kooperanti, koji učestvuju u izradi pojedinih komponenti za VABIS-ove proizvode. Proizvodnja se obavlja u nekoliko različitih odeljenja: preseraj, livnica, mašinska obrada, vrši izradu pozicija koji se ugrađuju u okov, zatim svi elementi odlaze u galvanizaciju, gde se vrši površinska zaštita. Zaštićeni elementi se transportuju u magacin poluproizvoda, a odatle na montažnu liniju gde se vrši sklapanje elemenata, uz 100% kontrolu svih elemenata koji silaze sa monta ne trake. VABIS poseduje sopstvenu razvojnu službu i sopstvenu laboratoriju za ispitivanje okova u kojima se svaki pojedinačni deo okova pažljivo konstruiše, a zatimi dugotrajno ispituje u simuliranim najtežim uslovima eksploatacije koje okov može da ima na terenu.

Takođe posedujemo veoma dobro opremljenu alatnicu za izradu alata za sopstvene potrebe, sa CNC mašinama, koje nam omogućavaju izradu kvalitetnih alata, a samim tim i gotovih proizvoda.



VABIS D.O.O. Aleksinac is founded in 1987 in Aleksinac as a small workshop and developed in several phases

- In 1992 started to produce turn door and window fittings
- In 1995 started to produce tilt and turn window fittings for wooden windows
- In 2000 started to produce tilt and turn window fittings for PVC windows
- In 2007 Started to produce tilt and turn window fittings for Aluminium windows
- In 2008 gains TUV-NORD certificate for QMS according to EN ISO 9001:2000
- In 2011 resertification of quality management system and gaining new certificate EN ISO 9001:2008
- In 2011 we gain the certificate according to EN 12400 and EN 13115 from one of the famous institute IFT Rosenheim
- In 2015 we gain the certificate according to EN 13126-16 for lift and slide window hardware, from one of the famous institute IFT Rosenheim

VABIS D.O.O. today is widely respected firm with more than 80 employees of which one part works directly in VABIS D.O.O. and others are cooperants. We produce our elements in several departments: diecasting department, department with presses, galvanizing department, department of automatic lathes, special tools department... Vabis D.O.O has his own development department and his own testing laboratory where every single part is tested in every possible condition. All elements are passing 100% control all along production line.



О КОМПАНИИ ...

Компания «Вабис» основана в 1987 году в г.Алексинач, республика Югославия ,как небольшое предприятие, хронология развития компании:

- 1992г. производство поворотных комплектов фурнитуры для окон и дверей
- 1995г. Производство поворотно - откидной фурнитуры для деревянных окон и дверей
- 2000г. Производство поворотно - откидной фурнитуры для ПВХ конструкций
- 2007г. Производство поворотно - откидной фурнитуры для алюминиевых конструкций
- 2008 г. Получен сертификат TUV – NORD по организации производства и менеджмента стандарта EN ISO 9001:2000
- 2011 Ресертификация Сертификация системы качества и ISO 9001: 2008.
- 2011 Получен сертификат на фурнитуру согласно EN 12400 и EN 13115, в известном институте IFT Розенхайме
- 2015 Получен сертификат на фурнитуру согласно EN 13126-16 в знаменитом институте IFT Розенхайм.

Компания «Вабис» сегодня, одно из ведущих предприятий которое включает в себя несколько фирм .В интересах повышения качества и постоянного развития компании в производственном процессе есть отделения инженерии, гальванизации ,литья, отделение сборки и контроля качества. Указанный цикл производства позволяет добиться результата 100% контроля качественного исполнения всех этапов производства.

Компания «Вабис» располагает своей лабораторией испытаний изделий в которой предназначенные к выпуску элементы фурнитуры проходят детальный инженерный контроль и испытания функциональной надежности. Цеха предприятия оборудованы станками с ЧПУ что позволяет быстро и качественно выполнять необходимые изменения в комплектации фурнитуры согласно мировым тенденциям производства.



POLITIKA KVALITETA za 2016. god.

Politika kvaliteta se zasniva na marketinški orijentisanom poslovnom sistemu čiji je osnovni zadatak, kontinuirano zadovoljenje kupaca.

U tom pogledu utvrđeni su sledeći principi:

- 1. Kvalitet proizvoda koji u potpunost** zadovoljavaju zahteve, potrebe i očekivanja zainteresovanih strana su prvi poslovni prioriteti u svim našim procesima.
- 2. Ispunjavanje zahteva sistema** upravljanja kvalitetom, i poboljšanje njegove **efektivnosti je stalan zadatak svih zaposlenih u Vabis-u.**
Neprekidan razvoj novih proizvoda, usavršavanje postojećih i njihovo usaglašavanje sa pripadajućim standardima je jedna od osnova razvoja Vabis -a. Podizanje nivoa produktivnosti proizvodnje i kvaliteta izrade proizvoda **i alata se odvija u kontinuitetu** što se postiže i obezbeđenjem potrebnih resursa.
- 3. Unapređenje i poboljšanje partnerskih odnosa** sa kupcima i isporučiocima je **trajna orijentacija Vabis-a u okviru svog poslovanja.**
- 4. Cilj je povećanje udela** na postojećim tržištima, kao **i osvajanje novih**, što bi **donelo** u ovoj godini povećanje prodaje za 20%, na ukupno urađenih i prodatih 500 000 prosečnih **garnitura.**
- 5. Sprovođenje zaštite životne sredine** u Vabisu se vrši u skladu sa važećim **zakonskim propisima.**
- 6. Naš cilj u 2016 . godini** je da podignemo broj urađenih garniturana na **350** prosečnih garnitura po jednom radniku na mesečnom nivou.
- 7. Automatizacija procesa** montaže delova je prioritet u investicijama, kao i instalacija nove opreme u livnici i galvanizaciji.
- 8. Maksimalna zaštita zdravlja i bezbednosti** na radu zaposlenih je jedno od **opredeljenja rukovodstva Vabis-a**, što podrazumeva poštovanje zakonskih odredbi. Stalno unapređenje zdravlja i bezbednosti zaposlenih sa neprekidnim preduzimanjem preventivnih mera radi sprečavanja **opasnosti i rizika svih vrsta, je osnovni cilj rukovodstva Vabis-a.**
- 9. Redovno pratimo i analiziramo efektivnost** naših procesa troškove kvaliteta, zdravlja i informišemo zaposlene o ukupno ostvarenim poslovnim rezultatima.

21.12.2015 god.

Generalni direktor
Vanko Stošić

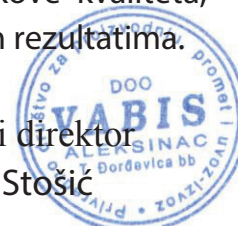

CERTIFICATE

TÜV NORD

Management system as per
EN ISO 9001 : 2008

In accordance with TÜV NORD CERT procedures, it is hereby certified that

VABIS D.O.O.
18220 Aleksinac
street Tihomira Djordjevica bb
Serbia



applies a management system in line with the above standard for the following scope

Design, development, manufacture and distribution of building hardware for doors and windows

Certificate Registration No. 44 100 080241
Audit Report No. 3513 3547

Valid until 2017-02-21
Initial certification 2008

G. Brüntigam
Certification Body
at TÜV NORD CERT GmbH

Essen, 2014-03-28

This certification was conducted in accordance with the TÜV NORD CERT auditing and certification procedures and is subject to regular surveillance audits.

TÜV NORD CERT GmbH

Langemarckstrasse 20

45141 Essen

www.tuev-nord-cert.com



TGA-ZM-07-06-00



Uredjaj za ispitivanje okova



Uredjaj za ispitivanje korozijske postojnosti

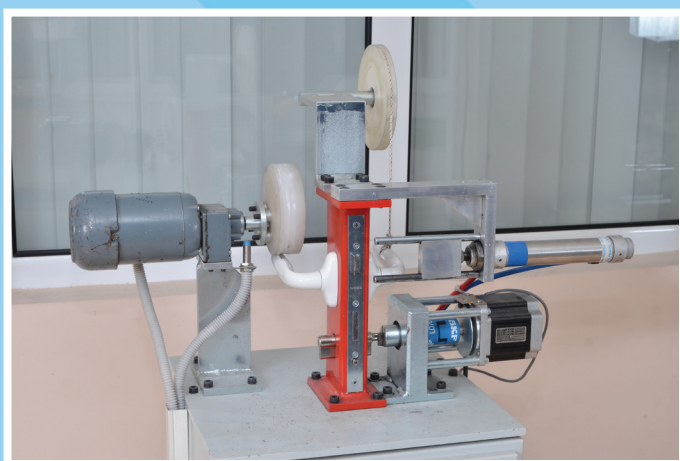

Uredjaj za testiranje izdržljivosti brave i kvake



Uredjaj za ispitivanje zupčaste letve

Nachweis

Baubeschläge, Beschläge für Fenster und Fenstertüren
gemäß EN 13126-16 : 2008

Prüfbericht

Nr. 14-000698-PR02

(PB-G05-03-de-03)



Auftraggeber VABIS d.o.o.
Tihomira Djordjevica bb
18220 Aleksinac
Serbien

Produkt Hebeschiebe-Beschlag für Fenster und Fenstertüren

Bezeichnung Lift & Slide hardware

Leistungsrelevante Produktdetails Flügelaußenmaß (B x H): 1240 mm x 1920 mm;
Rahmenmaterial: Aluminium mit thermischer Trennung
Flügelgewicht: 250 kg,
Beschlag: Lift & Slide hardware / VABIS d.o.o.
Ausführung Flügelbeschlag: Hebe-Schiebe,
Beschreibung der blendrahmenseitigen Beschlagsausführung:
Führungsschiene oben: entspricht Blendrahmenprofil,
Führungsschiene unten: Art.-Nr.: F-1112,
Laufwagen: 92009 und 92018

Besonderheiten -/-

Grundlagen

EN 13126-1 : 2011
EN 13126-16:2008-01

Prüfnormen:
EN 13126-16:2008-01

Entsprechende nationale Fassungen (z.B. DIN EN)

Prüfbericht 14-000698-PR02
(PB-G05-03-de-02) vom
23.03.2015

Darstellung



Verwendungshinweise

Dieser Prüfbericht dient zum Nachweis der Anforderungen von Fensterbeschlägen gemäß EN 13126-16:2008.

Die Bestimmungen aus EN 13126-16:2008 zur Kennzeichnung und Konformitätsbewertung der Bauprodukte sind zu beachten.

Gültigkeit

Die genannten Daten und Einzelergebnisse beziehen sich ausschließlich auf den geprüften/ beschriebenen Probekörper. Die Klassifizierung gilt so lange bis das Produkt unverändert ist und die o.g. Grundlagen sich nicht geändert haben. Das Ergebnis kann unter Beachtung entsprechender Festlegungen der Produktnorm in Eigenverantwortung des Herstellers übertragen werden. Diese Prüfung/Bewertung ermöglicht keine Aussage über weitere leistungs- und qualitätsbestimmende Eigenschaften der vorliegenden Konstruktion; insbesondere Witterungs- und Alterungseinflüsse wurden nicht berücksichtigt.

Veröffentlichungshinweise

Es gilt das ift-Merkblatt "Werbung mit ift-Prüfdokumentationen". Das Deckblatt kann als Kurzfassung verwendet werden.

Der Nachweis umfasst insgesamt 20 Seiten.

Ergebnis

Klassifizierung gemäß EN 13126-16 : 2008

Ge- brauchs- kategorie	Dauer- funktions- tüchtigkeit	Masse	Feuerbe- ständig- keit	Ge- brauchs- sicherheit	Korrosi- ons- bestän- digkeit	Schutz- wirkung	Anwen- dung	Prüf- größen
-	4	250	0	1	4	-	16	1240 / 1920 *

*Vom Antragsteller wurden Probekörpergrößen angeliefert, welche nicht den Verhältnismäßigkeiten der EN 13126-16, Abschnitt 4.10 entsprechen

ift Rosenheim

09.04.2015

Konrad Querengässer, Dipl.-Ing. (FH)
Prüfstellenleiter
Sicherheitstechnik

Pascal Geiger, Dipl.-Ing. (FH)
Produktioningenieur
Bauteile

KLIZNO PODIZNI SISTEM

LIFT AND SLIDE

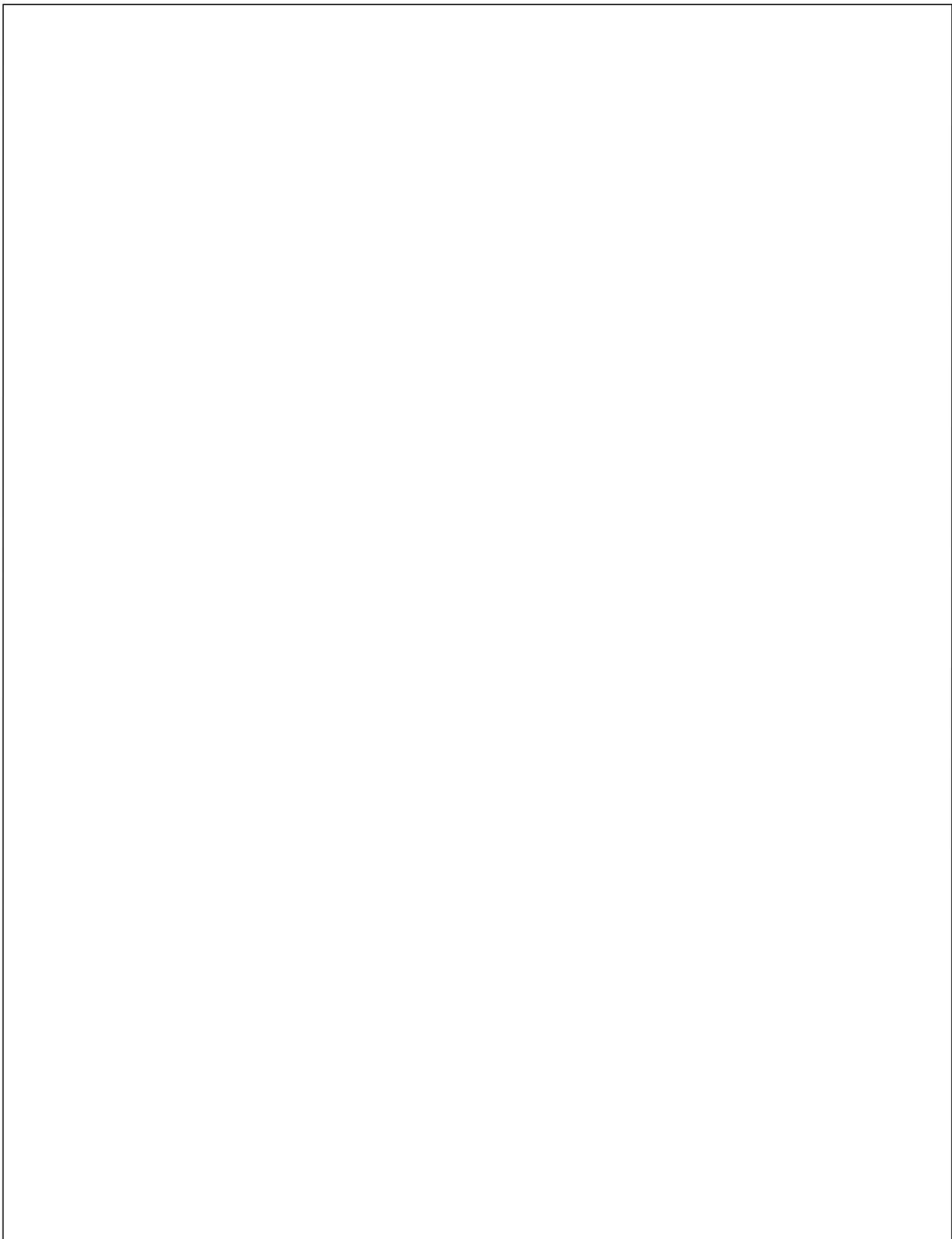

*Klizno podizni sistem za
Aluminijum 250kg*

*Lift and slide system for
Aluminum 250kg*

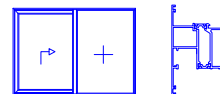

Alumil M300

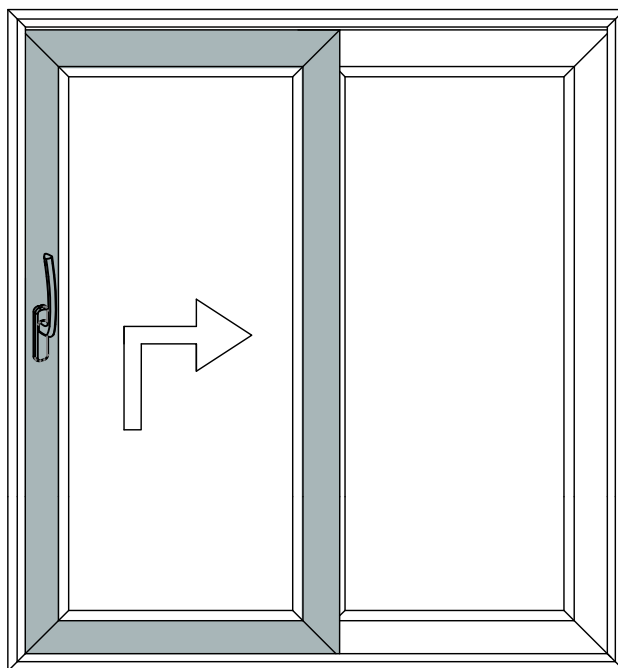
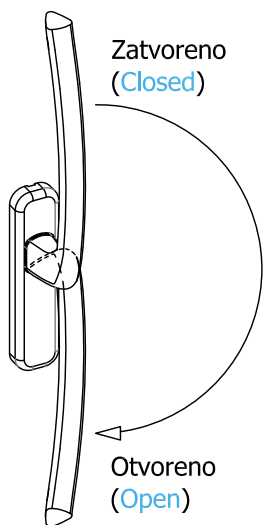

Raspored krila / Sash arrangement

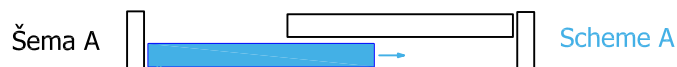

Tehnički podaci / Technical Data

Širina krila / Sash width 700 - 3250 mm
 Visina krila / Sash height 1150 - 2760 mm
 Spoljna širina okvira / Outer frame width 6500 mm

Nosivost krila / Sash weight max. 250 kg

Visina ručice / Handle position

Prozor / Window 408,5 mm
 Vrata / Door 1008,5 mm

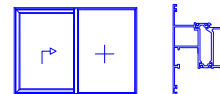

Alumil M300

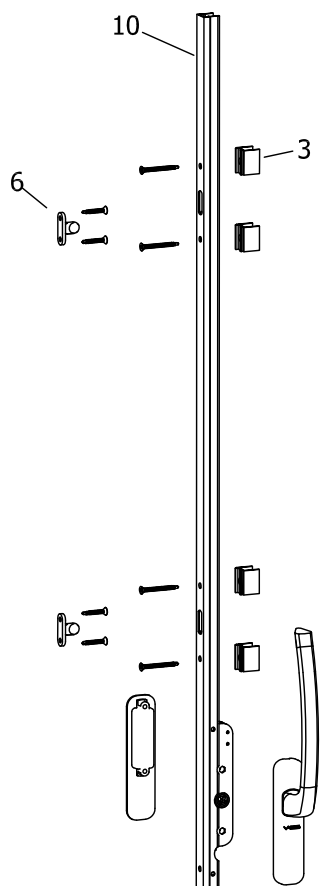

Klizno podizni sistem / Lift and slide system									
Poz. / Pos.	Naziv elementa / Name	Šifra / Code	Šifra naručivanja / Order code	Sema / Scheme					
				A	D	C	F		
1	Prednja kolica / Front rollers	92520	set 94210	1	1	1	2		
2	Zadnja kolica / Back rollers	92620							
3	Podmetač profila brave / Cover for door lock	92074							
4	Podmetač kolica bočni / Plastic cover side	92084							
5	Graničnik / Limiter	94020							
6	Zabavljivač / Lock	92767							
7	Oslonac kolica - prednji / Bogie support	94110							
8	Oslonac kolica - zadnji / Bogie support	94115							
9	Spojka kolica / Rollers connector	DK / FB	Dužina spojke / Length rollers connector	1	2	2	4		
		700-1500	750					92305	92305
		1501-1750	1000					92310	92310
		1751-2250	1500					92315	92315
		2251-2750	2000					92320	92320
10	Profil brave / Door lock profil	VK / FH	Dužina brave / Length door lock	1	2	2	4		
		1150-1760	1700					92205	92205
		1830-2260	2200					92245	92245
		2080-2760	2700					92285	92285
11	Pomoćna kolica (za težine krila preko 250 kg) / Assistance rollers (for weight > 250 kg)	92660	92660						

Klizno podizni sistem / Lift and slide						
Poz. / Pos.	Naziv elementa / Name	Šifra / Code	set 94210	set 94212	set 94214	set 94216
			Kom. / Pes.	Kom. / Pes.	Kom. / Pes.	Kom. / Pes.
1	Prednja kolica / Front rollers	92520	1	1	1	1
2	Zadnja kolica / Back rollers	92620	1	1	1	1
3	Podmetač profila brave / Cover for door lock	92074	6	6	6	6
4	Podmetač kolica bočni / Plastic cover side	92084	1	1	1	1
5	Graničnik / Limiter	94020	2	-	2	-
6	Zabavljivač / Lock	92767	3	3	-	-
7	Oslonac kolica - prednji / Bogie support	94110	1	1	1	1
8	Oslonac kolica - zadnji / Bogie support	94115	2	2	2	2

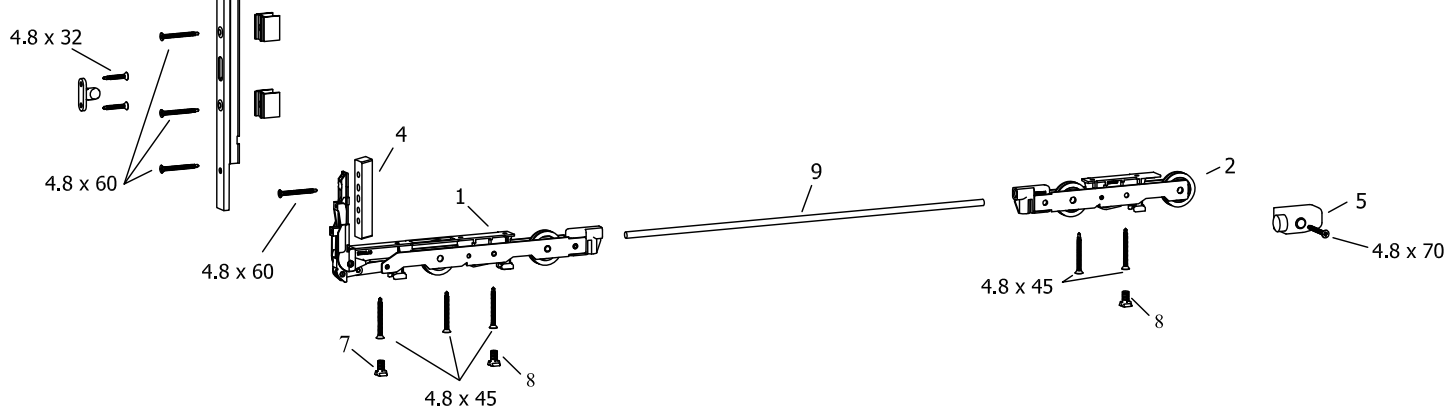

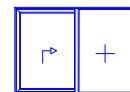

Alumil M300

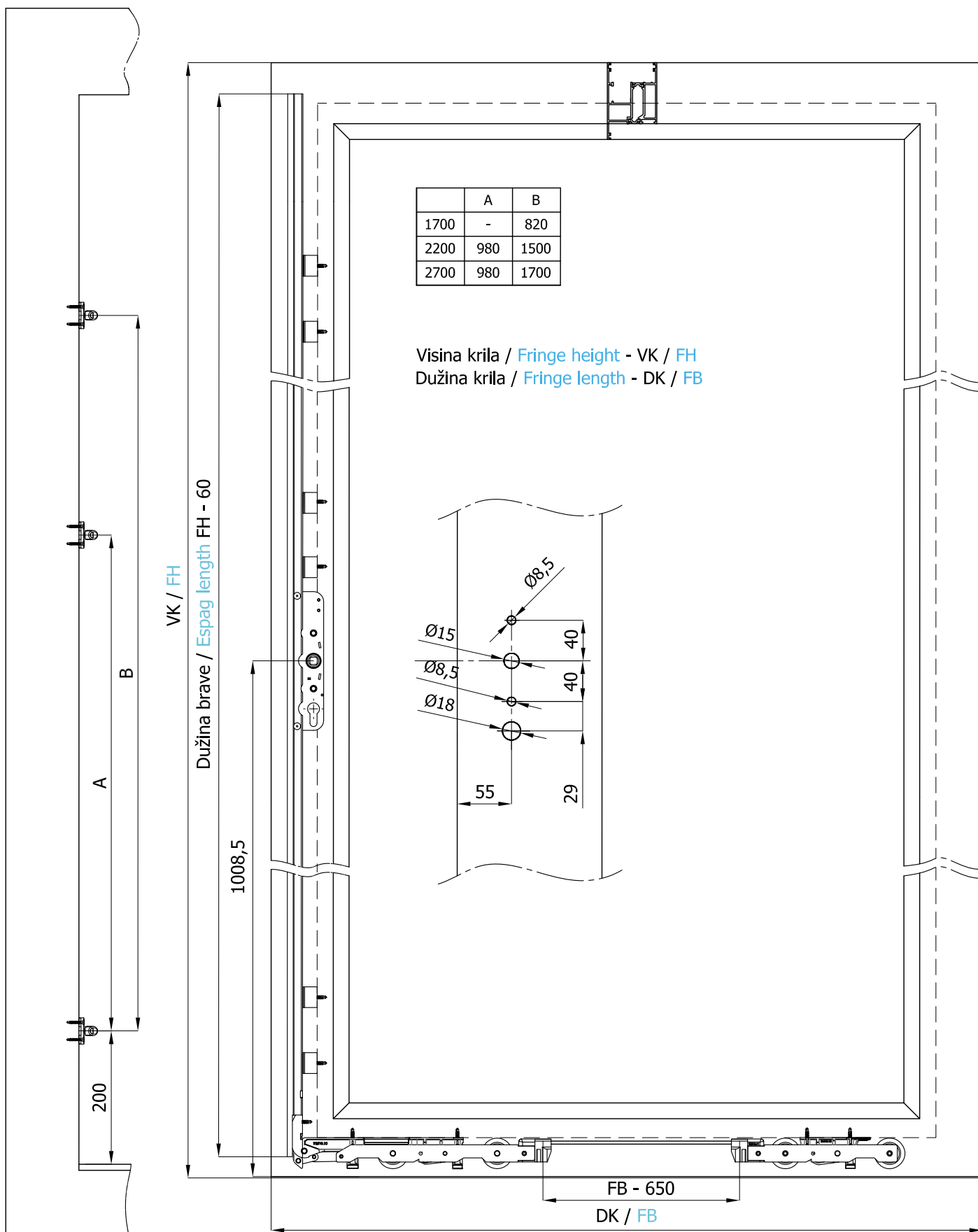

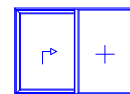

Alumil M300

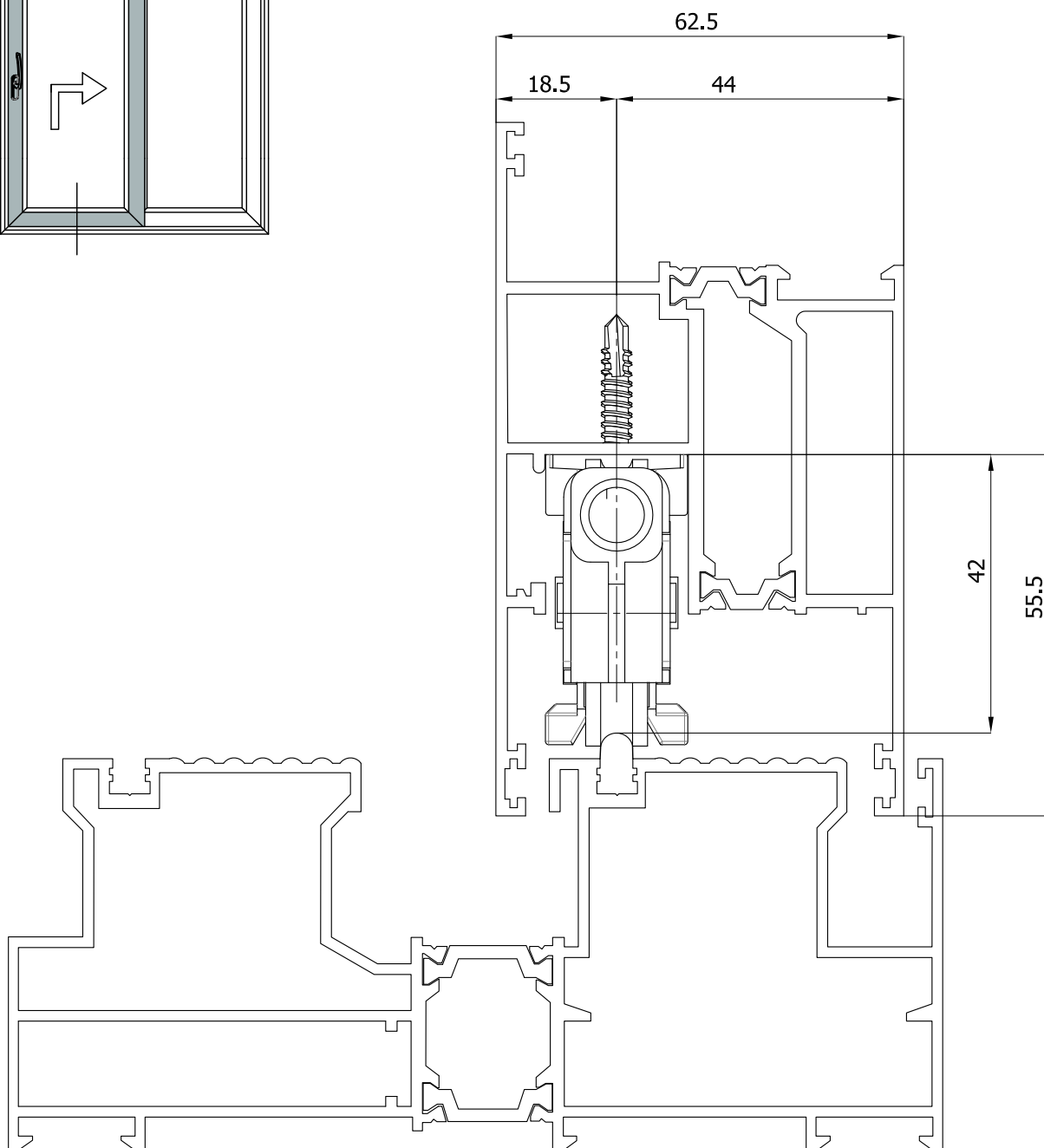
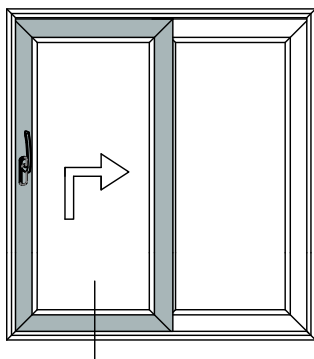

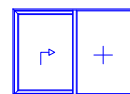

Alumil M300

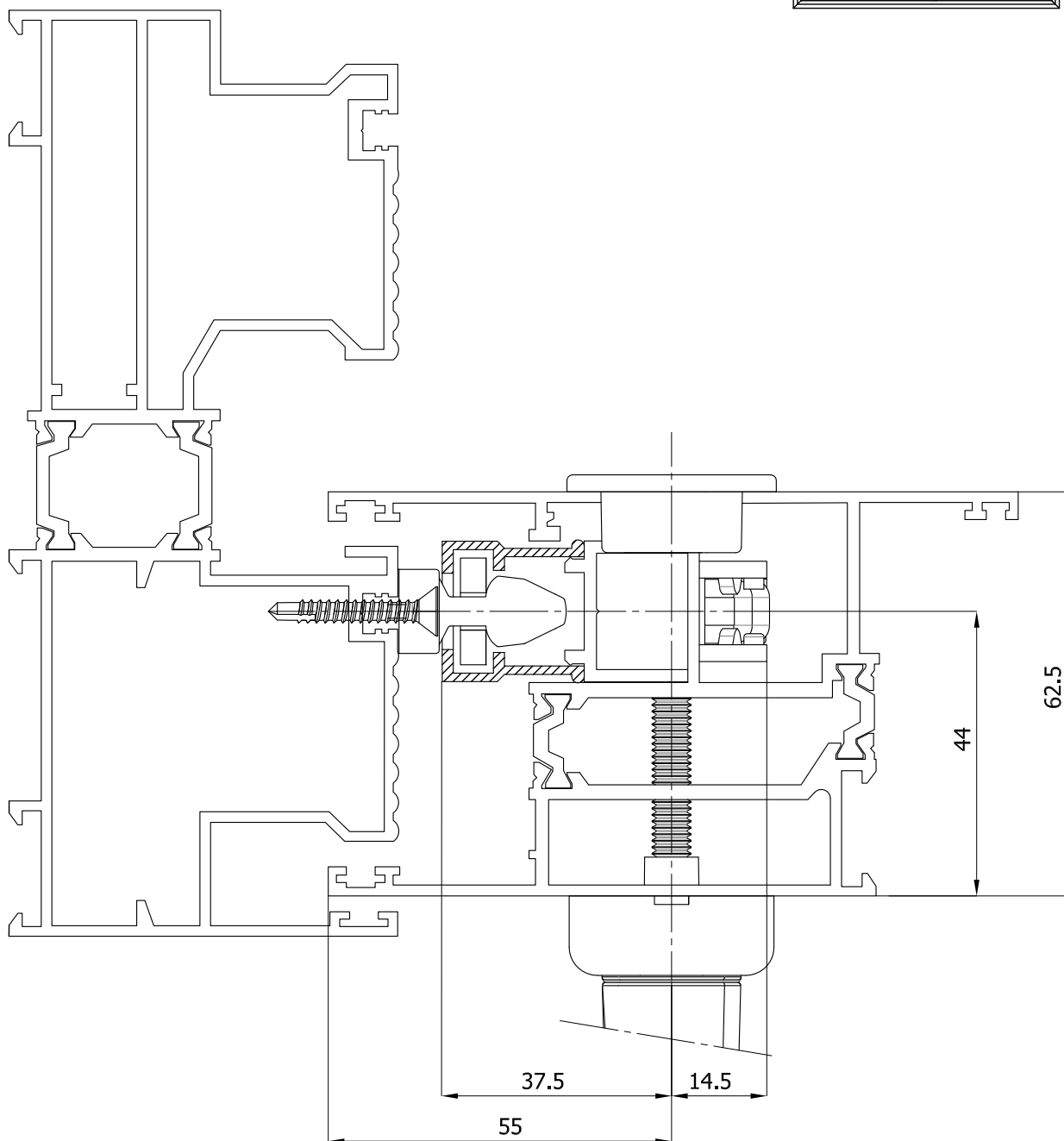
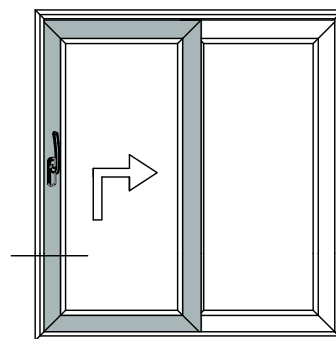

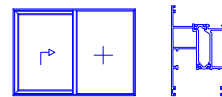

Alumil M300

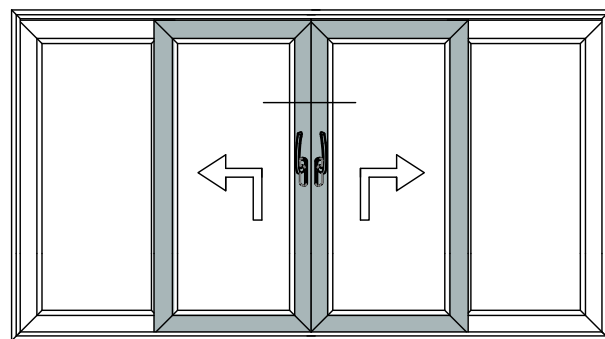
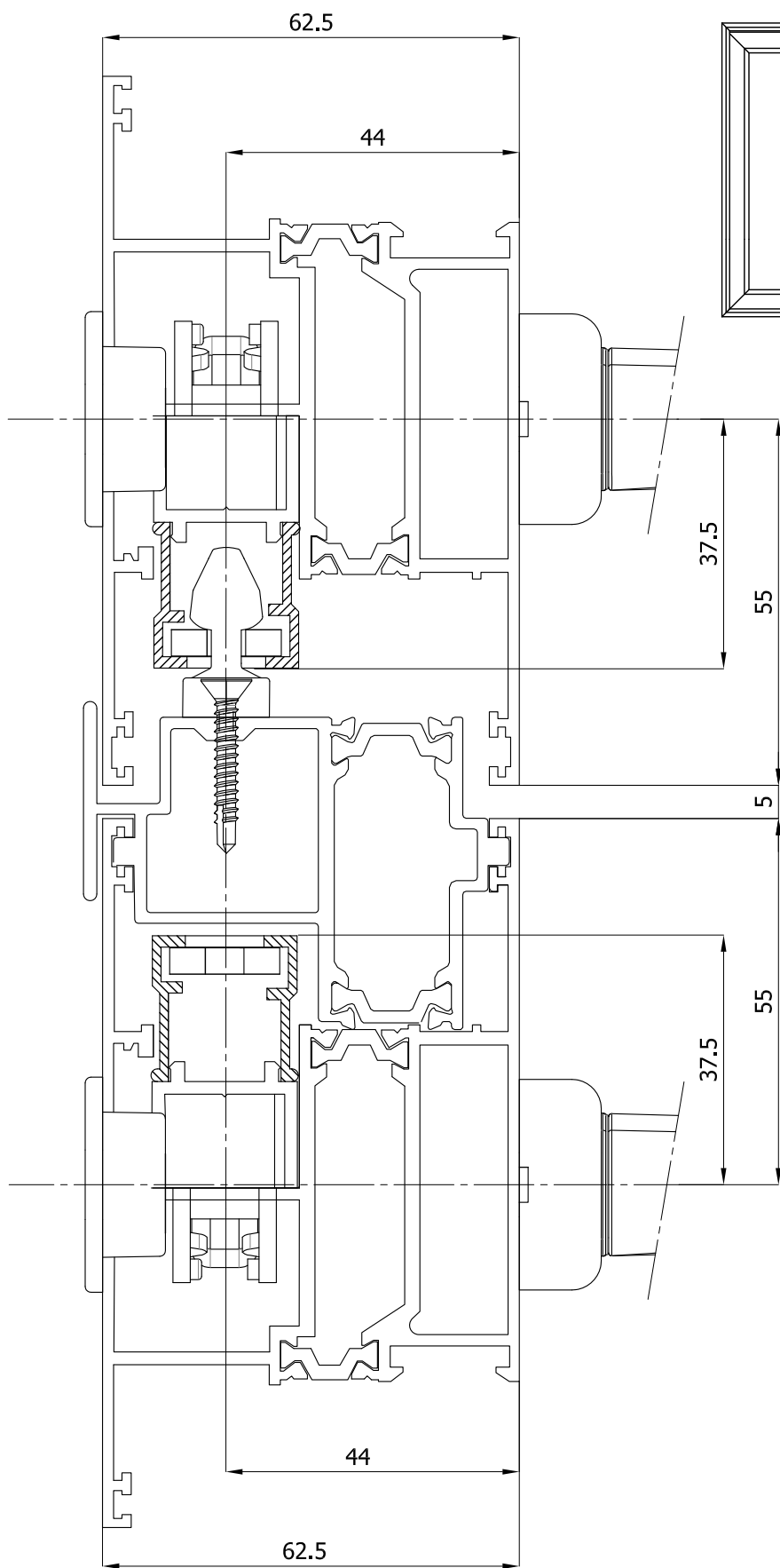

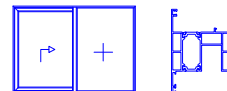

Exalco Albio 230

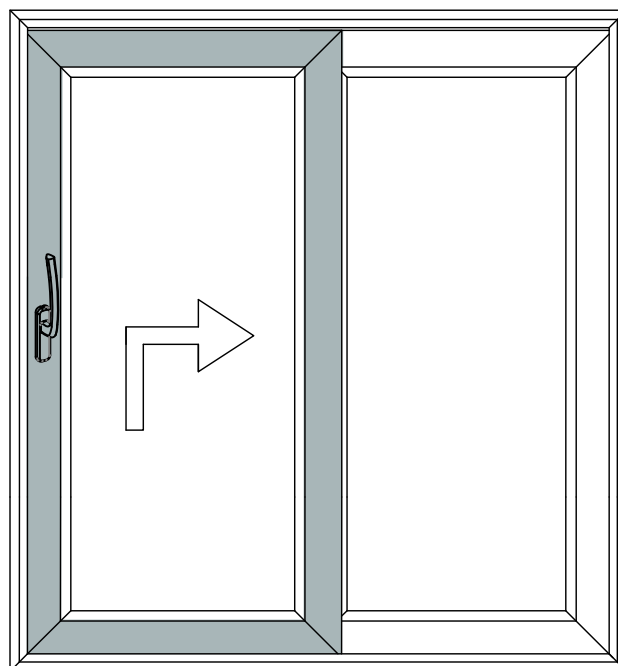
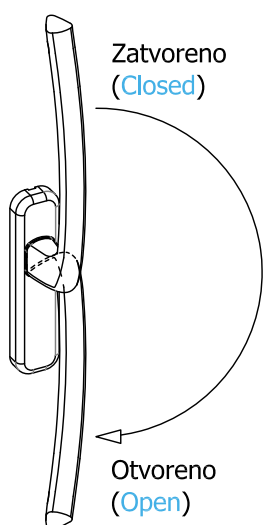

Raspored krila / Sash arrangement

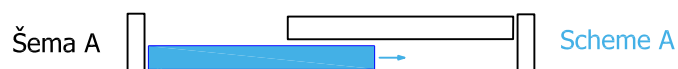

Tehnički podaci / Technical Data

Širina krila / Sash width 700 - 3250 mm
 Visina krila / Sash height 1150 - 2760 mm
 Spoljna širina okvira / Outer frame width 6500 mm

Nosivost krila / Sash weight max. 250 kg

Visina ručice / Handle position

Prozor / Window 407,7 mm
 Vrata / Door 1007,7 mm

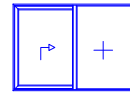

Exalco Albio 230

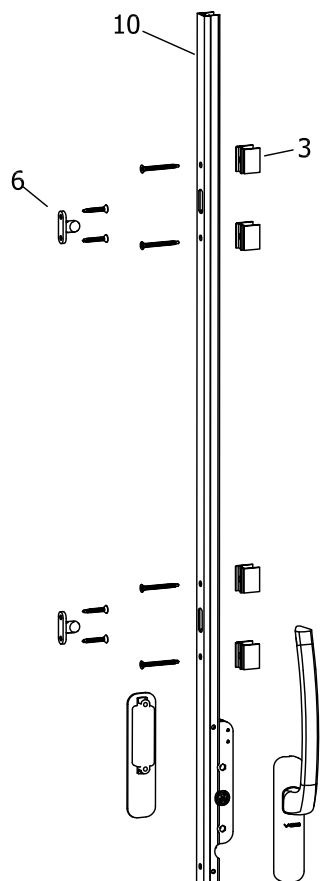

Klizno podizni sistem / Lift and slide system									
Poz. / Pos.	Naziv elementa / Name	Šifra / Code	Šifra naručivanja / Order code	Sema / Scheme					
				A	D	C	F		
1	Prednja kolica / Front rollers	92520	set 94230 set 94232 set 94234 set 94236	1	1	1	2		
2	Zadnja kolica / Back rollers	92620							
3	Podmetač profila brave / Cover for door lock	92079							
4	Podmetač kolica bočni / Plastic cover side	92089							
5	Graničnik / Limiter	94020							
6	Zabavljivač / Lock	92761							
7	Oslonac kolica - prednji / Bogie support	94110							
8	Oslonac kolica - zadnji / Bogie support	94115							
9	Spojka kolica / Rollers connector	DK / FB	Dužina spojke / Length rollers connector	1	2	2	4		
		700-1500	750					92305	92305
		1501-1750	1000					92310	92310
		1751-2250	1500					92315	92315
		2251-2750	2000					92320	92320
10	Profil brave / Door lock profil	VK / FH	Dužina brave / Length door lock	1	2	2	4		
		1150-1760	1700					92205	92205
		1830-2260	2200					92245	92245
		2080-2760	2700					92285	92285
11	Pomoćna kolica (za težine krila preko 250 kg) / Assistance rollers (for weight > 250 kg)	92660	92660						

Klizno podizni sistem / Lift and slide						set 94230	set 94232	set 94234	set 94236
Poz. / Pos.	Naziv elementa / Name	Šifra / Code	Kom. / Pes.	Kom. / Pes.	Kom. / Pes.	Kom. / Pes.	Kom. / Pes.	Kom. / Pes.	
1	Prednja kolica / Front rollers	92520	1	1	1	1			
2	Zadnja kolica / Back rollers	92620	1	1	1	1			
3	Podmetač profila brave / Cover for door lock	92079	6	6	6	6			
4	Podmetač kolica bočni / Plastic cover side	92089	1	1	1	1			
5	Graničnik / Limiter	94020	2	-	2	-			
6	Zabavljivač / Lock	92761	3	3	-	-			
7	Oslonac kolica - prednji / Bogie support	94110	1	1	1	1			
8	Oslonac kolica - zadnji / Bogie support	94115	2	2	2	2			

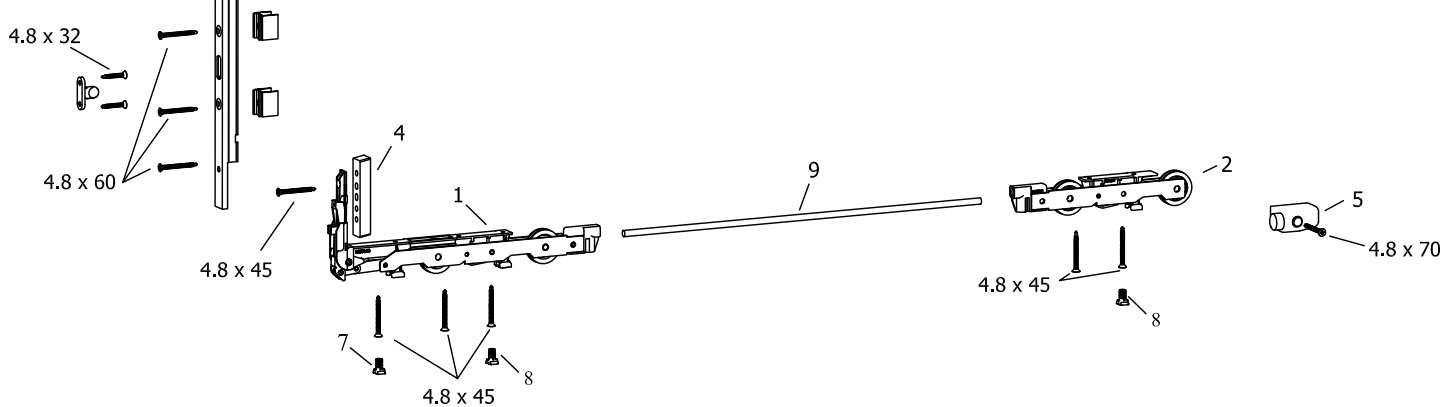

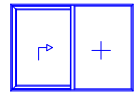

Exalco Albio 230

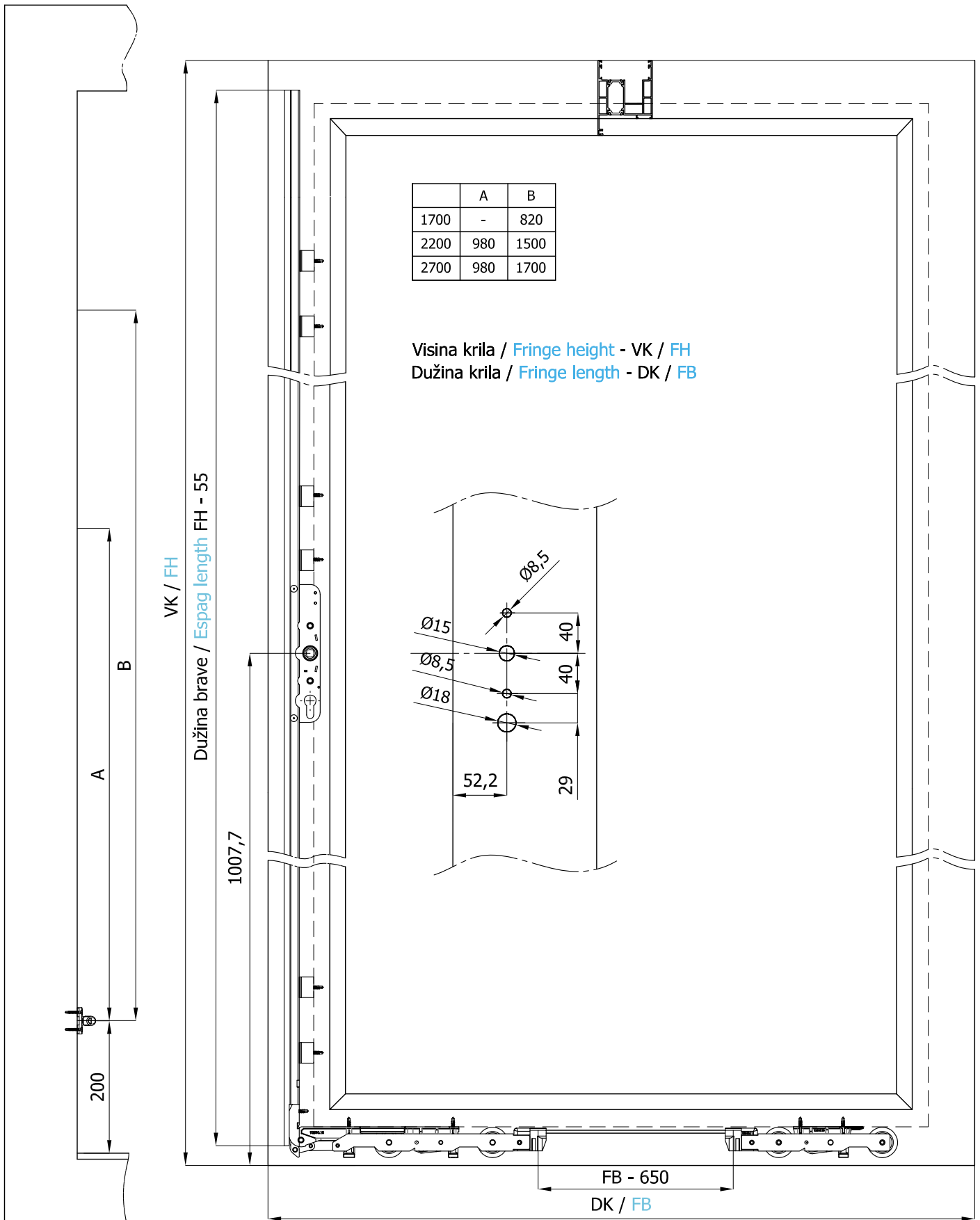

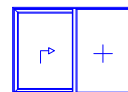

Exalco Albio 230

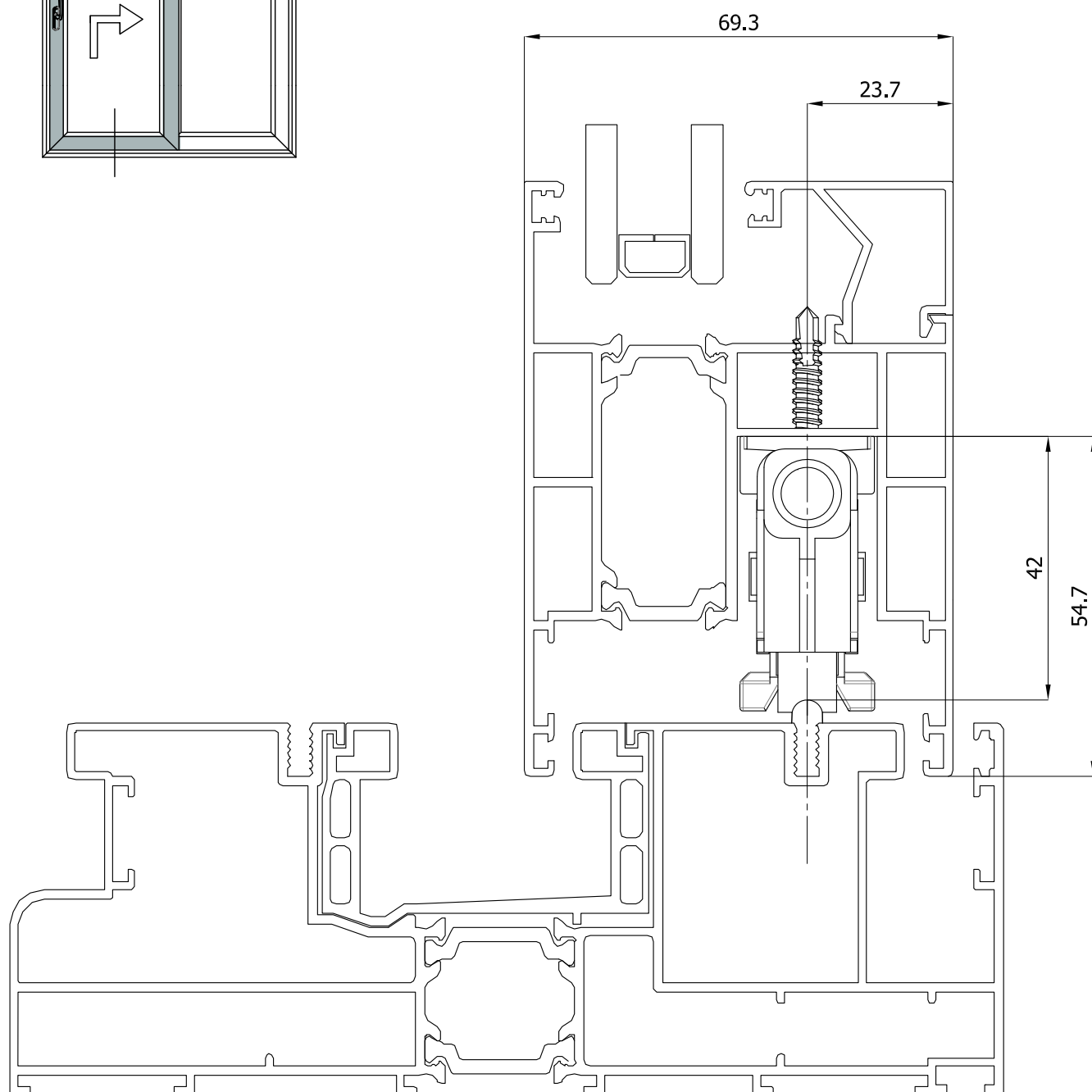
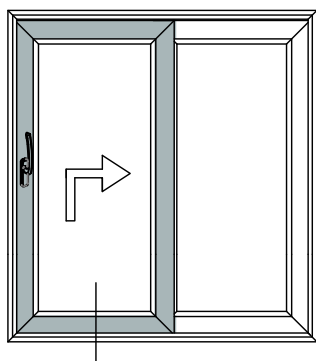

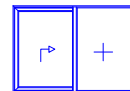

Exalco Albio 230

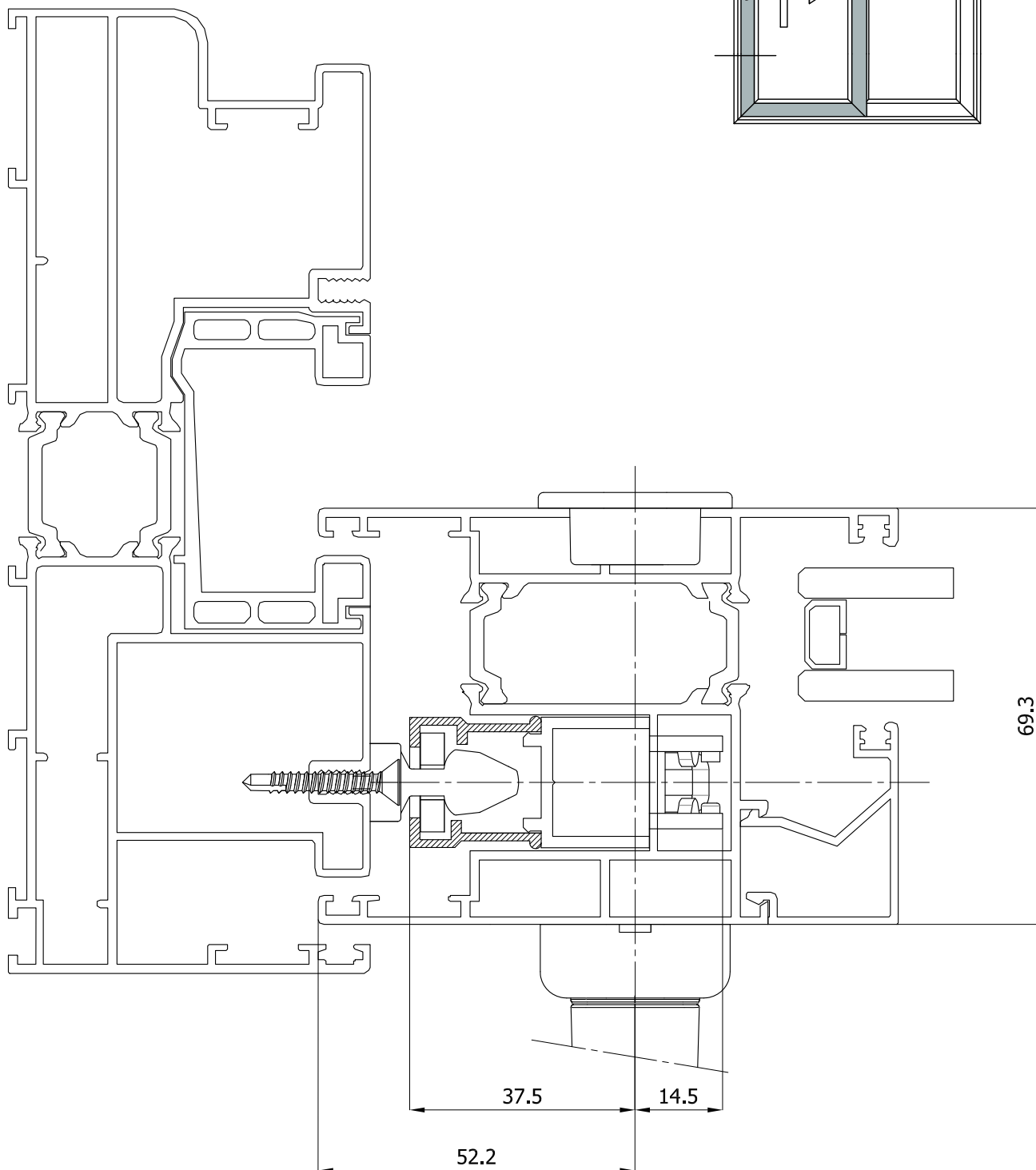
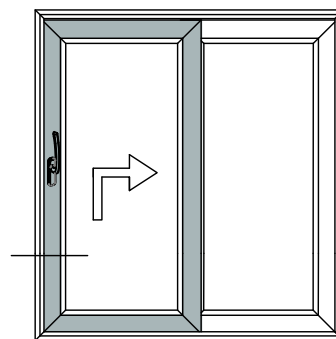

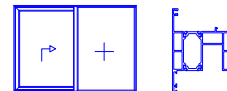

Exalco Albio 230

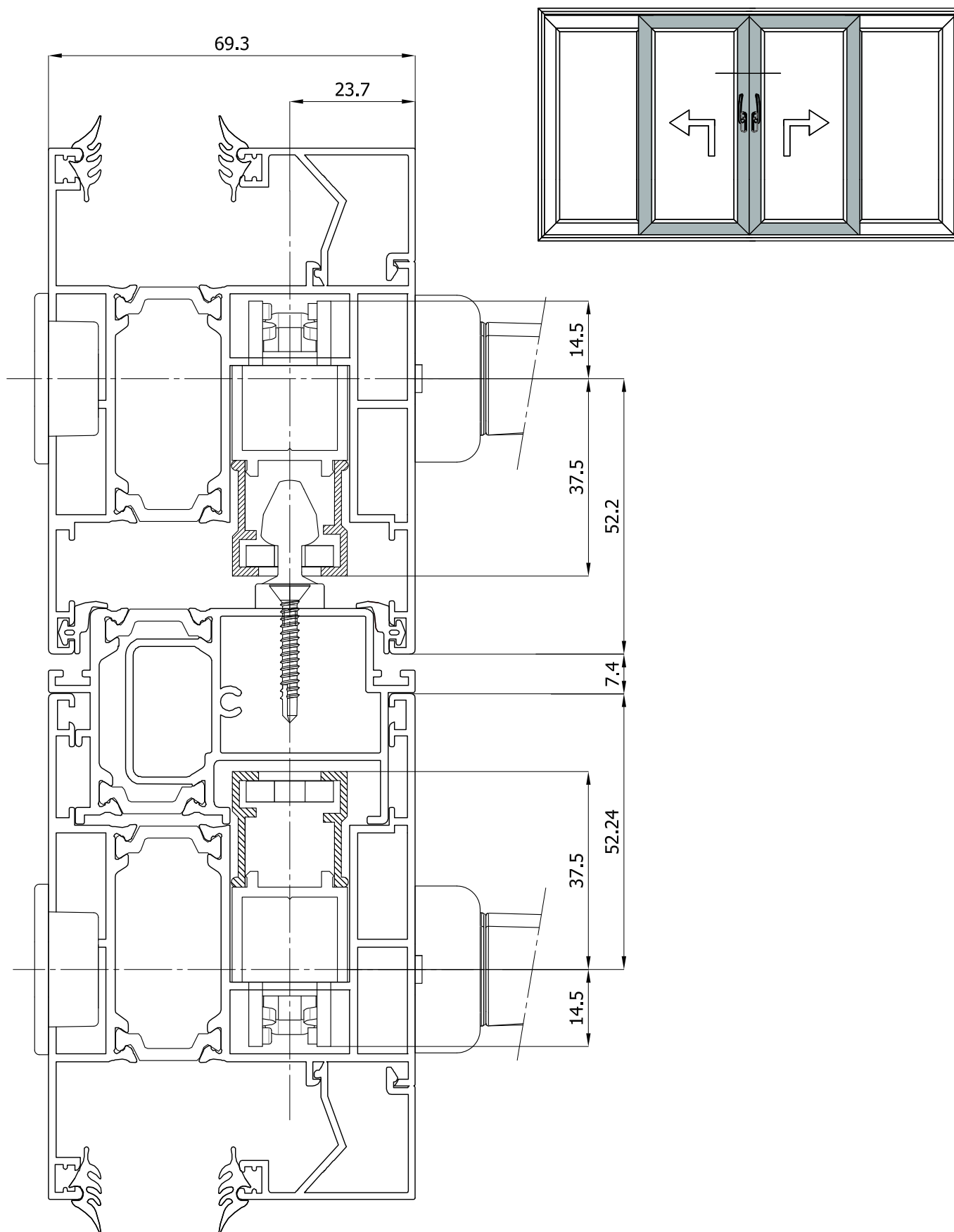

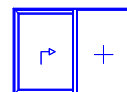

Elvial 6800

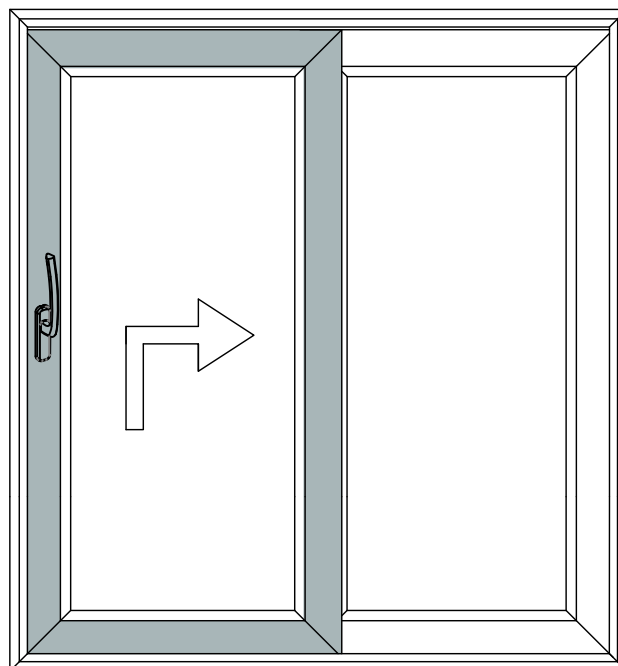
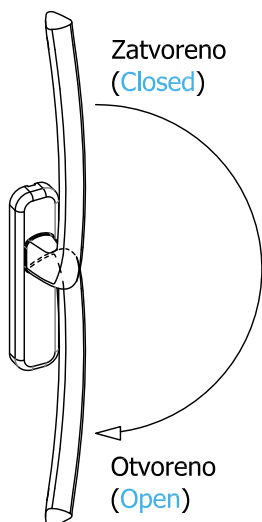

Raspored krila / Sash arrangement

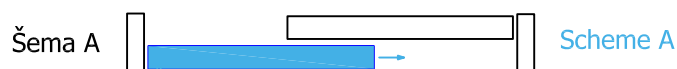

Tehnički podaci / Technical Data

Širina krila / Sash width 700 - 3250 mm
 Visina krila / Sash height 1150 - 2760 mm
 Spoljna širina okvira / Outer frame width 6500 mm

Nosivost krila / Sash weight max. 250 kg

Visina ručice / Handle position

Prozor / Window 407,2 mm
 Vrata / Door 1007,2 mm

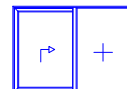

Elvial 6800

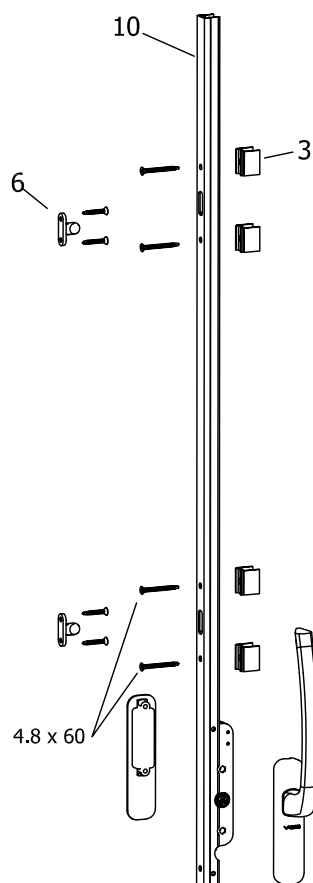

Klizno podizni sistem / Lift and slide system

Poz. Pos.	Naziv elementa / Name	Šifra / Code	Šifra naručivanja Order code	Sema / Scheme					
				A	D	C	F		
1	Prednja kolica / Front rollers	92520	set 94220 set 94222 set 94224 set 94226	1	1	1	2		
2	Zadnja kolica / Back rollers	92620		1	1	1	2		
3	Podmetač profila brave / Cover for door lock	92076		1	1	1	2		
4	Podmetač kolica bočni / Plastic cover side	92086		1	1	1	2		
5	Graničnik / Limiter	94020		1	1	1	2		
6	Zabravljivač / Lock	92763		1	1	1	2		
7	Oslonac kolica - prednji / Bogie support	94110		1	1	1	2		
8	Oslonac kolica - zadnji / Bogie support	94115		1	1	1	2		
9	Spojka kolica Rollers connector	DK / FB	Dužina spojke Length rollers connector	1	2	2	4		
		700-1500	750					92305	92305
		1501-1750	1000					92310	92310
		1751-2250	1500					92315	92315
		2251-2750	2000					92320	92320
10	Profil brave Door lock profil	VK / FH	Dužina brave Length door lock	1	2	2	4		
		1150-1760	1700					92205	92205
		1830-2260	2200					92245	92245
		2080-2760	2700					92285	92285
11	Pomoćna kolica (za težine krila preko 250 kg) Assistance rollers (for weight > 250 kg)	92660	92660						

Klizno podizni sistem / Lift and slide

Poz. Pos.	Naziv elementa / Name	Šifra / Code	Kom. / Kom.			
			set 94220 Pes.	set 94222 Pes.	set 94224 Pes.	set 94226 Pes.
1	Prednja kolica / Front rollers	92520	1	1	1	1
2	Zadnja kolica / Back rollers	92620	1	1	1	1
3	Podmetač profila brave / Cover for door lock	92079	6	6	6	6
4	Podmetač kolica bočni / Plastic cover side	92089	1	1	1	1
5	Graničnik / Limiter	94020	2	-	2	-
6	Zabravljivač / Lock	92763	3	3	-	-
7	Oslonac kolica - prednji / Bogie support	94110	1	1	1	1
8	Oslonac kolica - zadnji / Bogie support	94115	2	2	2	2

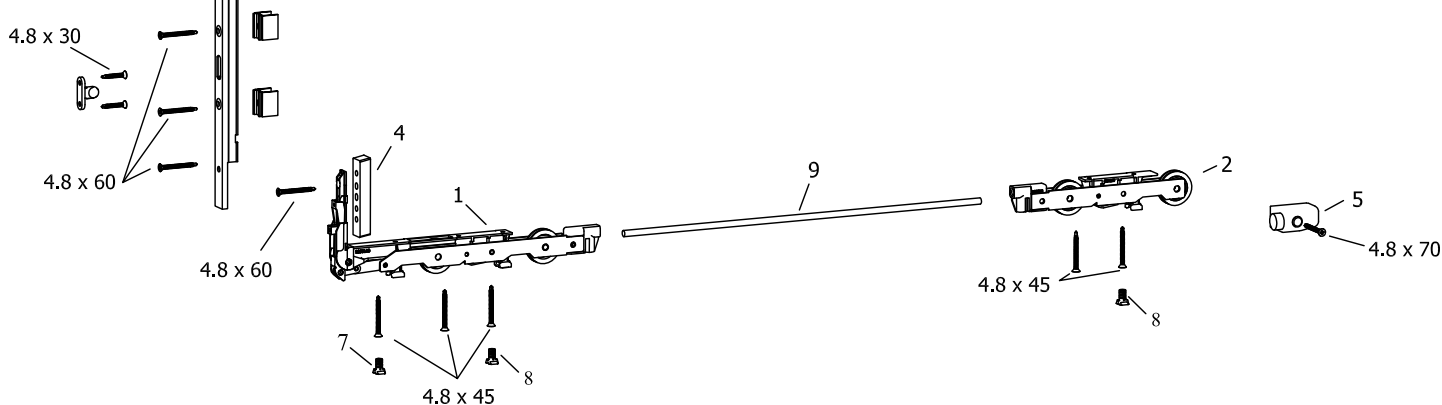

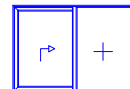

Elvial 6800

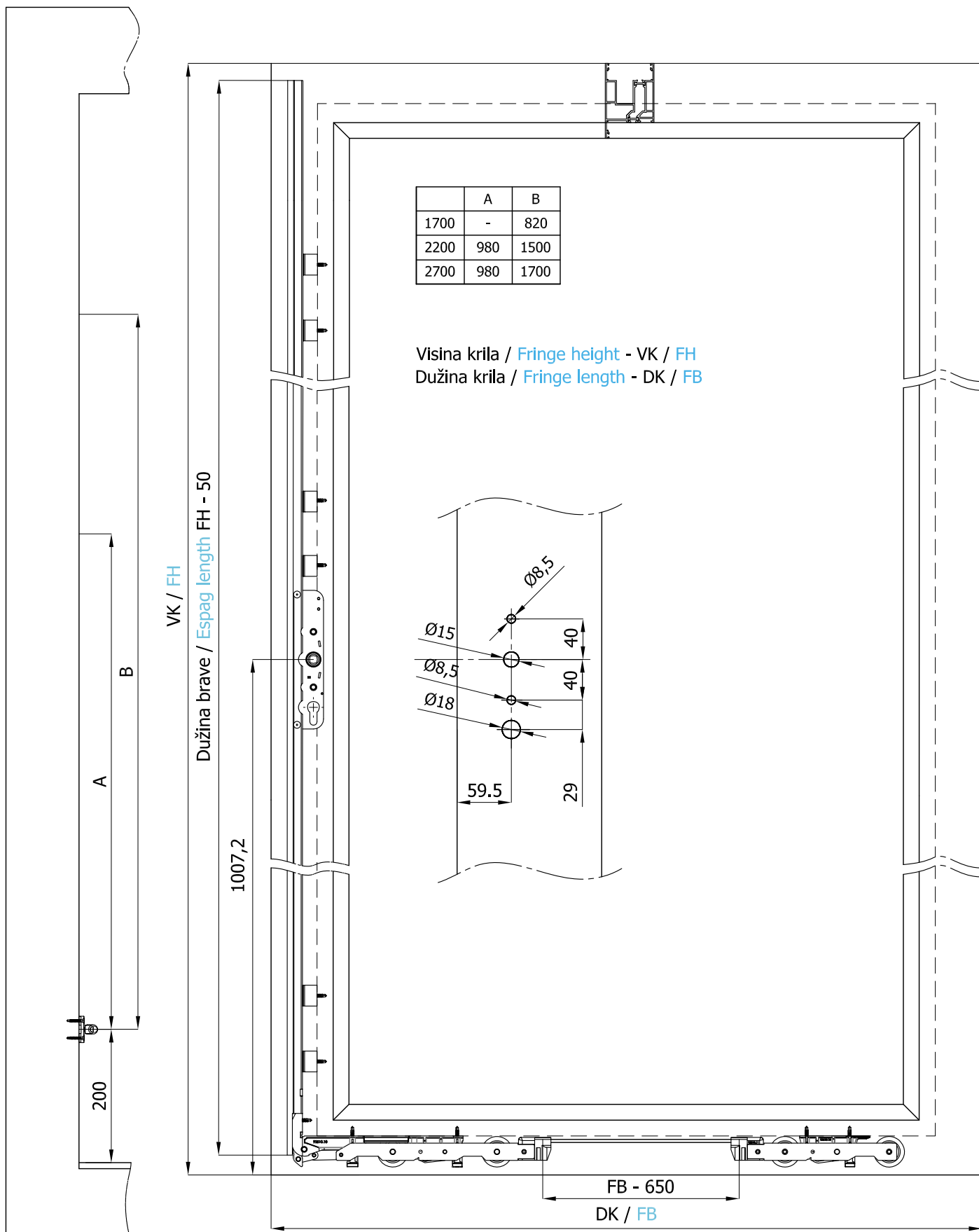

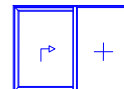

Elvial 6800

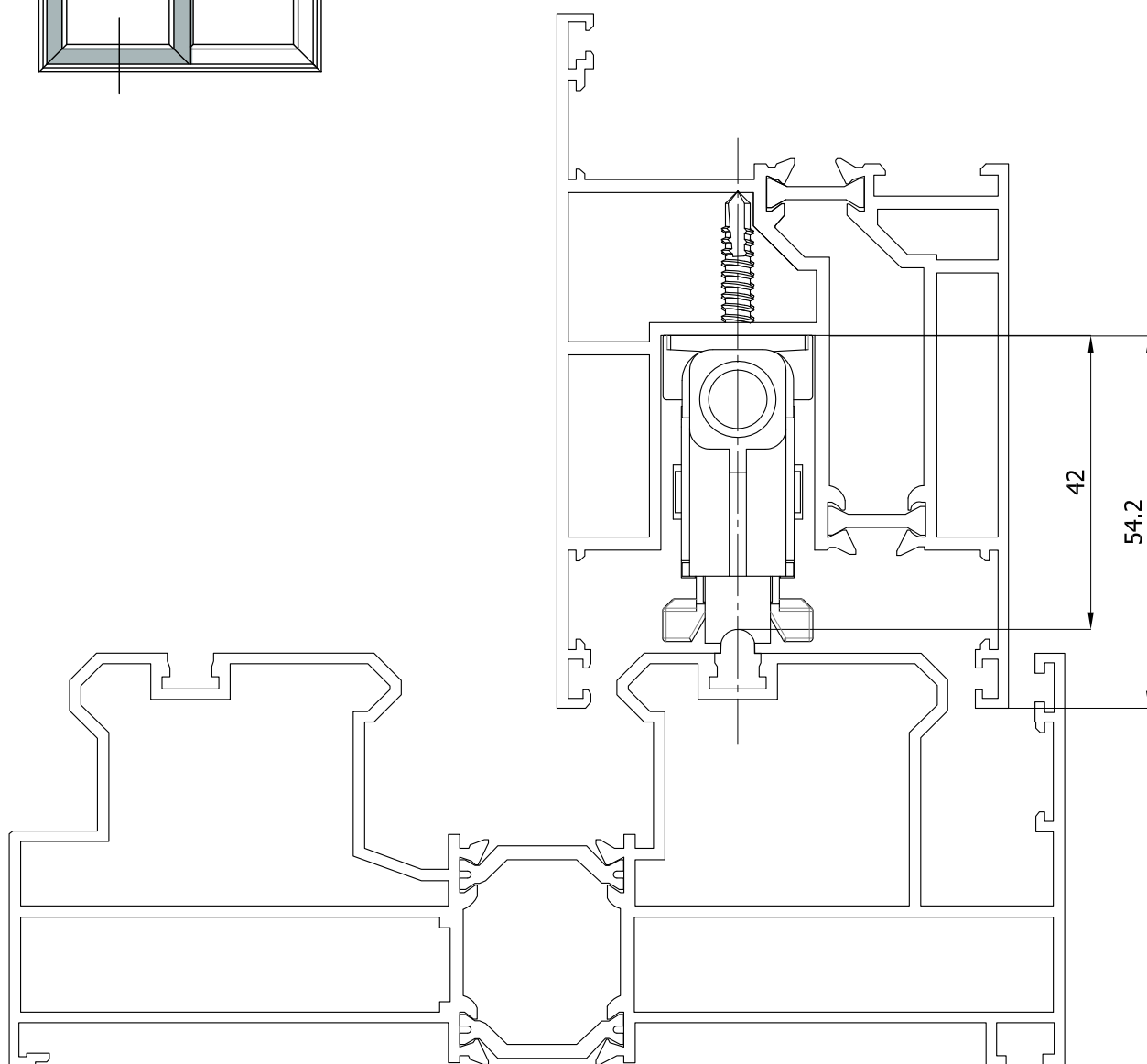
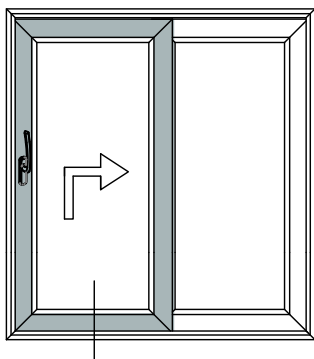

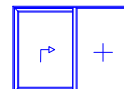

Elvial 6800

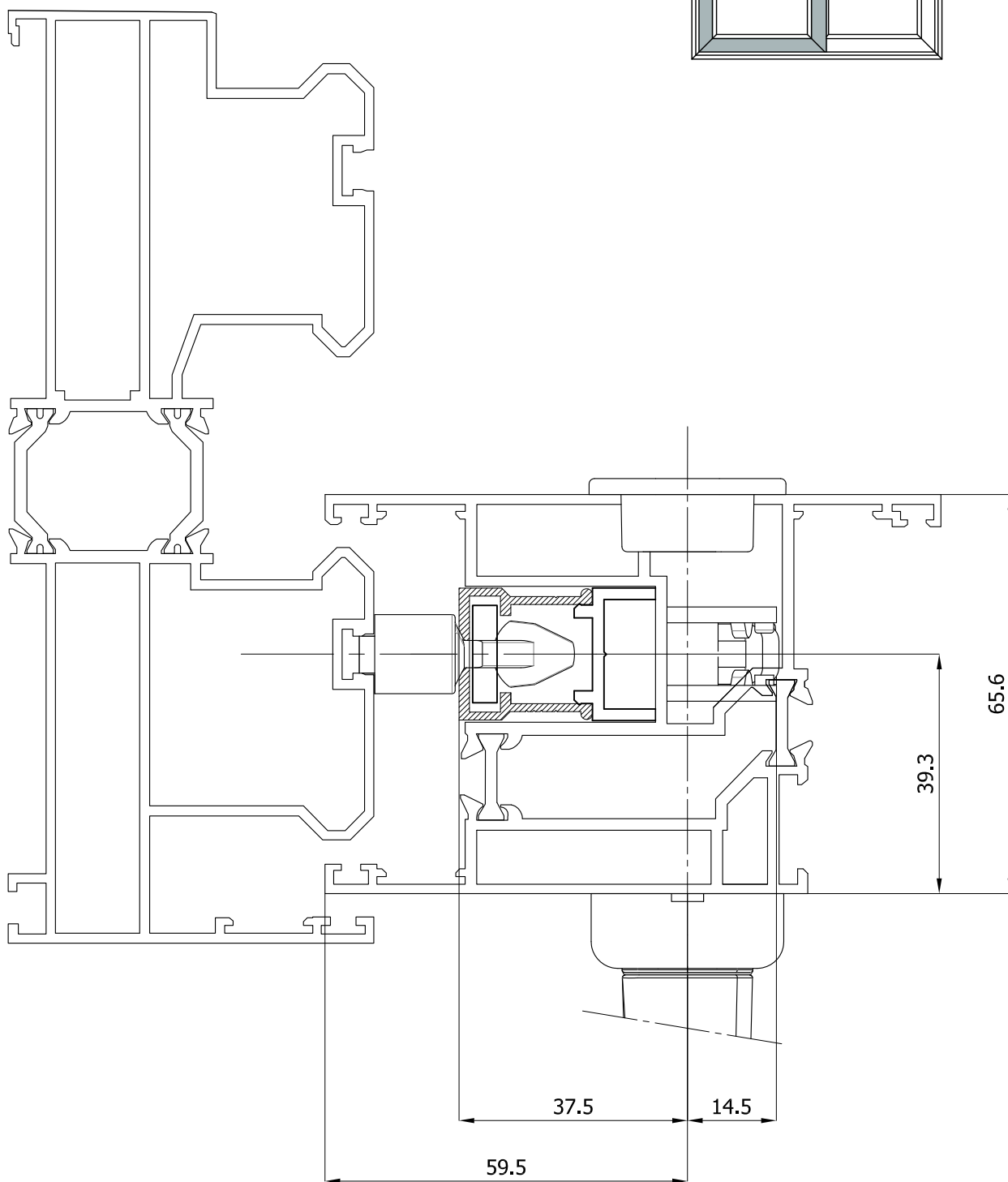
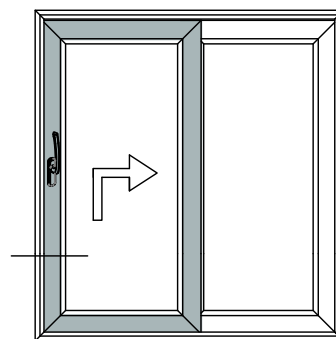

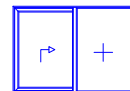

Elvial 6800

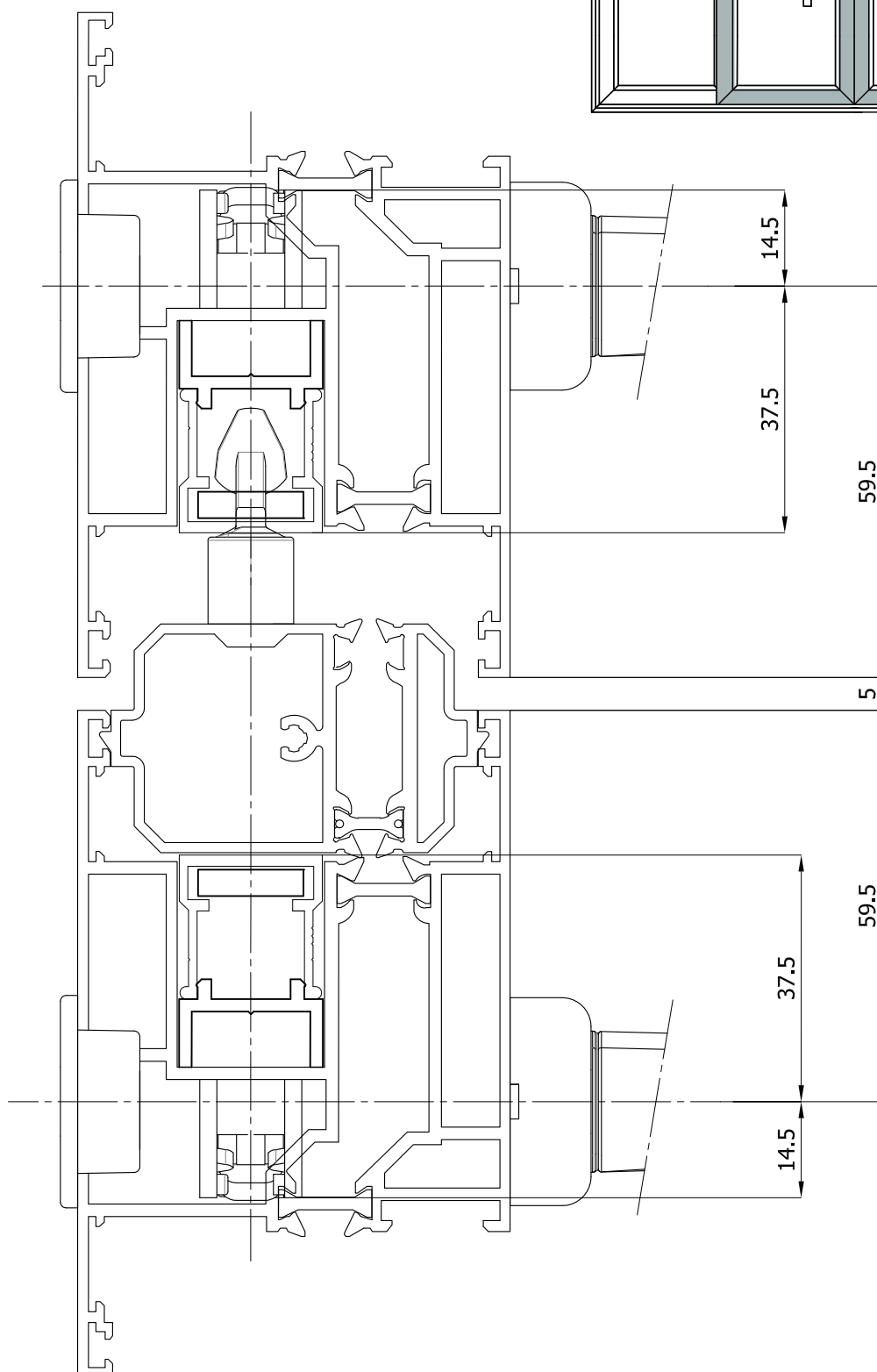
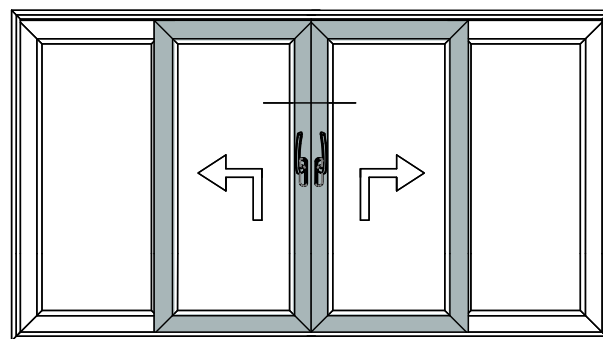

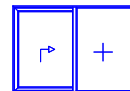

Etem E3000

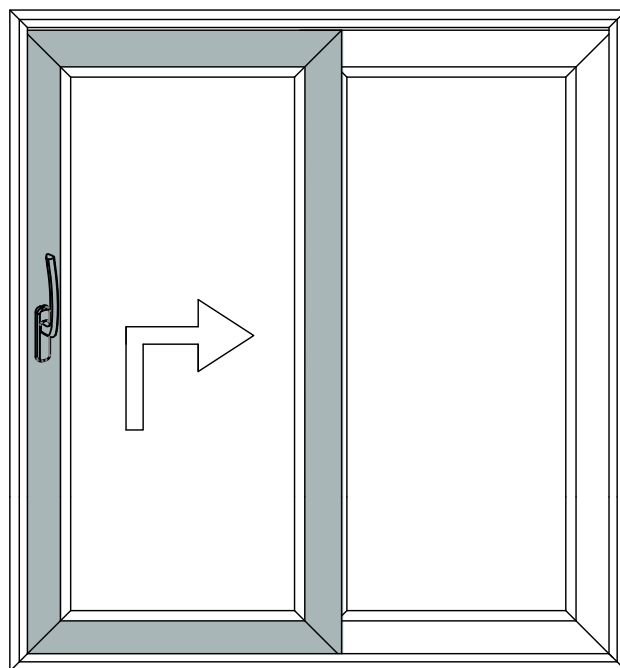
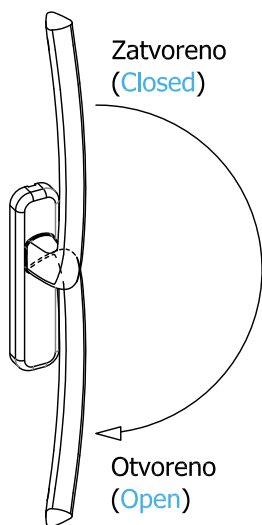

Raspored krila / Sash arrangement

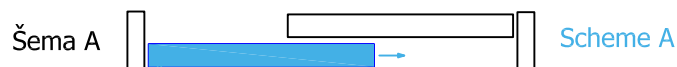

Tehnički podaci / Technical Data

Širina krila / Sash width 700 - 3250 mm
 Visina krila / Sash height 1150 - 2760 mm
 Spoljna širina okvira / Outer frame width 6500 mm

Nosivost krila / Sash weight max. 250 kg

Visina ručice / Handle position

Prozor / Window 407,5 mm
 Vrata / Door 1007,5 mm

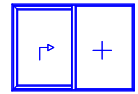

Etem E3000

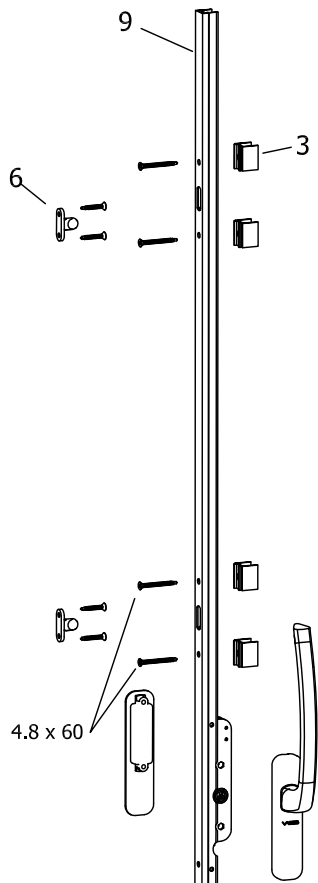

Klizno podizni sistem / Lift and slide system											
Poz. Pos.	Naziv elementa / Name	Šifra / Code	Šifra naručivanja / Order code	Sema / Scheme							
				A	D	C	F				
1	Prednja kolica / Front rollers	92520	set 94240	1	1	1	2				
2	Zadnja kolica / Back rollers	92620									
3	Podmetač profila brave / Cover for door lock	92077						set 94242	1	1	1
4	Podmetač kolica bočni / Plastic cover side	92087						set 94244	1	1	1
5	Graničnik / Limiter	94020						set 94246	1	1	1
6	Zabavljivač / Lock	92764									
7	Oslonac kolica - prednji / Bogie support	94110									
8	Oslonac kolica - zadnji / Bogie support	94115									
9	Spojka kolica / Rollers connector	DK / FB	Dužina spojke / length rollers connector	1	2	2	4				
		700-1500	750					92305	92305		
		1501-1750	1000					92310	92310		
		1751-2250	1500					92315	92315		
		2251-2750	2000					92320	92320		
10	Profil brave / Door lock profil	VK / FH	Dužina brave / Length door lock	1	2	2	4				
		1150-1760	1700					92205	92205		
		1830-2260	2200					92245	92245		
		2080-2760	2700					92285	92285		
11	Pomoćna kolica (za težine krila preko 250 kg) / Assistance rollers (for weight > 250 kg)	92660	92660								

Klizno podizni sistem / Lift and slide						set 94240	set 94242	set 94244	set 94246
Poz. Pos.	Naziv elementa / Name	Šifra / Code	Kom. Pes.	Kom. Pes.	Kom. Pes.	Kom. Pes.			
1	Prednja kolica / Front rollers	92520	1	1	1	1			
2	Zadnja kolica / Back rollers	92620	1	1	1	1			
3	Podmetač profila brave / Cover for door lock	92077	6	6	6	6			
4	Podmetač kolica bočni / Plastic cover side	92087	1	1	1	1			
5	Graničnik / Limiter	94020	2	-	2	-			
6	Zabavljivač / Lock	92764	3	3	-	-			
7	Oslonac kolica - prednji / Bogie support	94110	1	1	1	1			
8	Oslonac kolica - zadnji / Bogie support	94115	2	2	2	2			

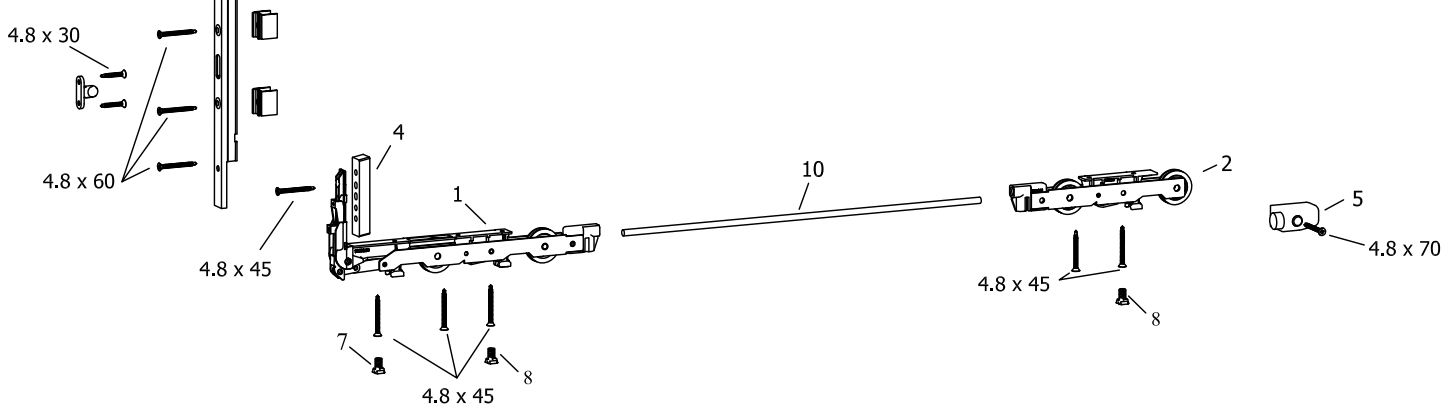

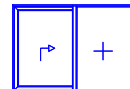

Etem E3000

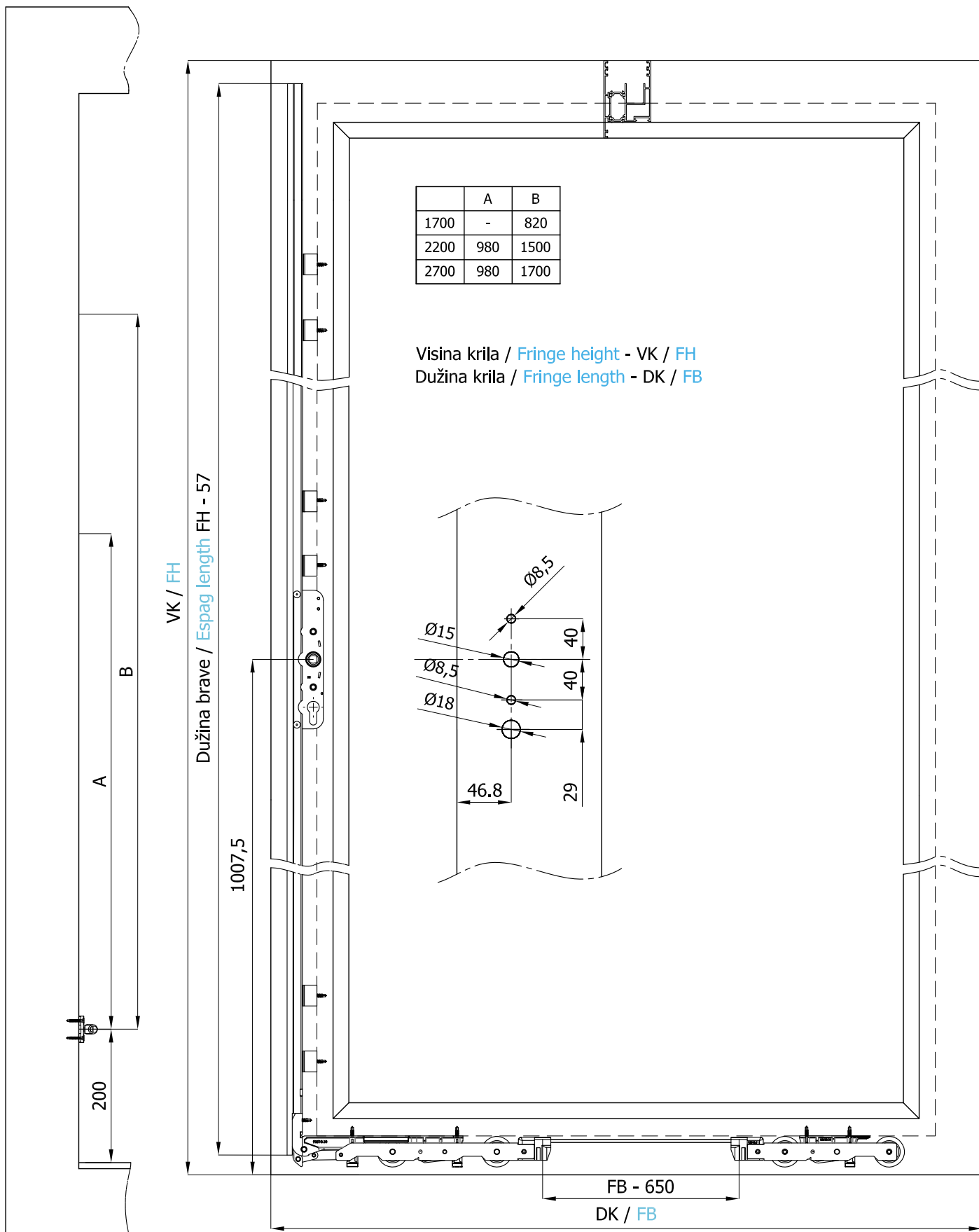

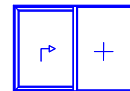

Etem E3000

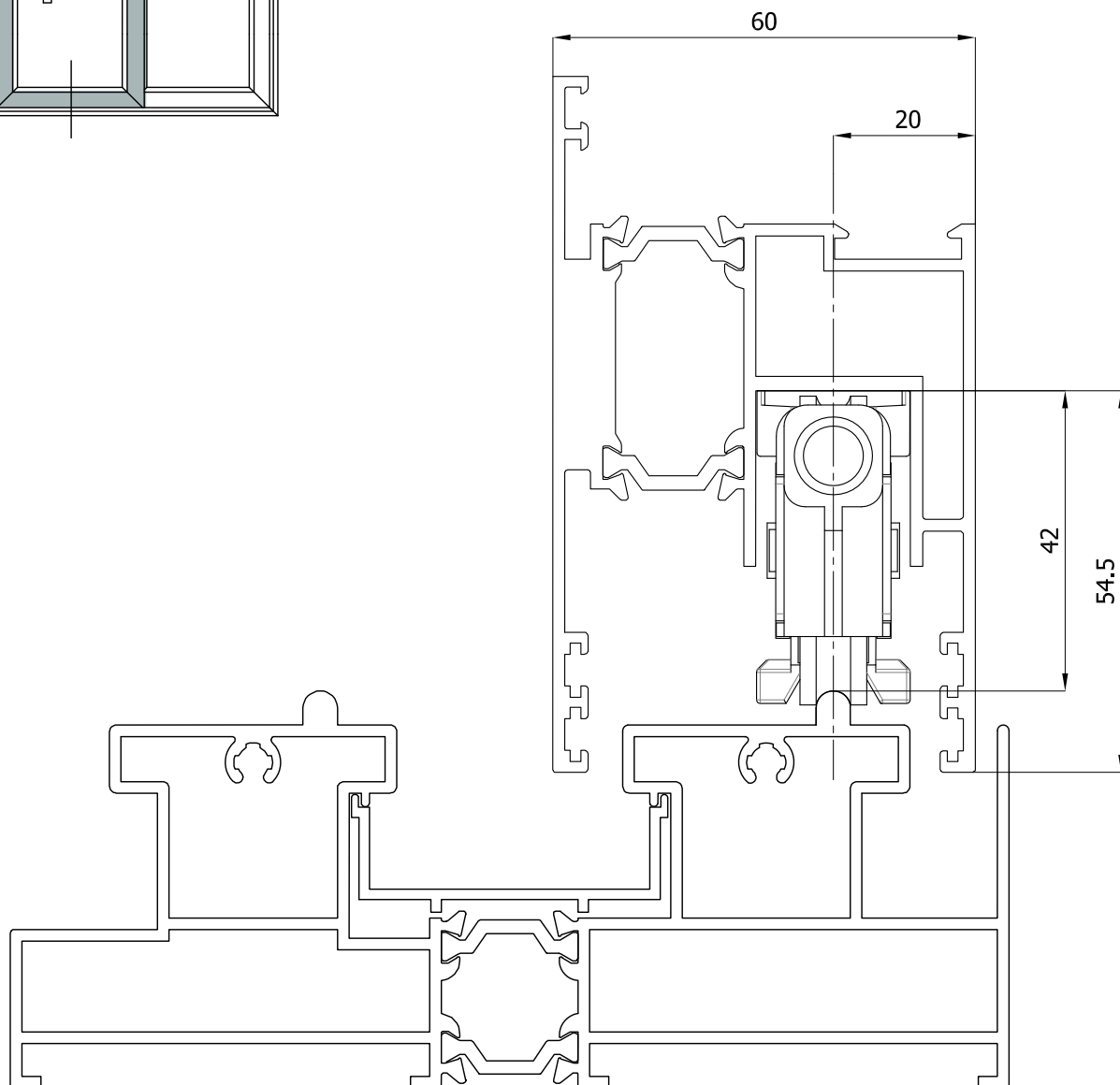
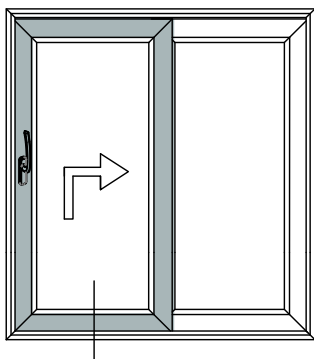

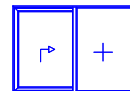

Etem E3000

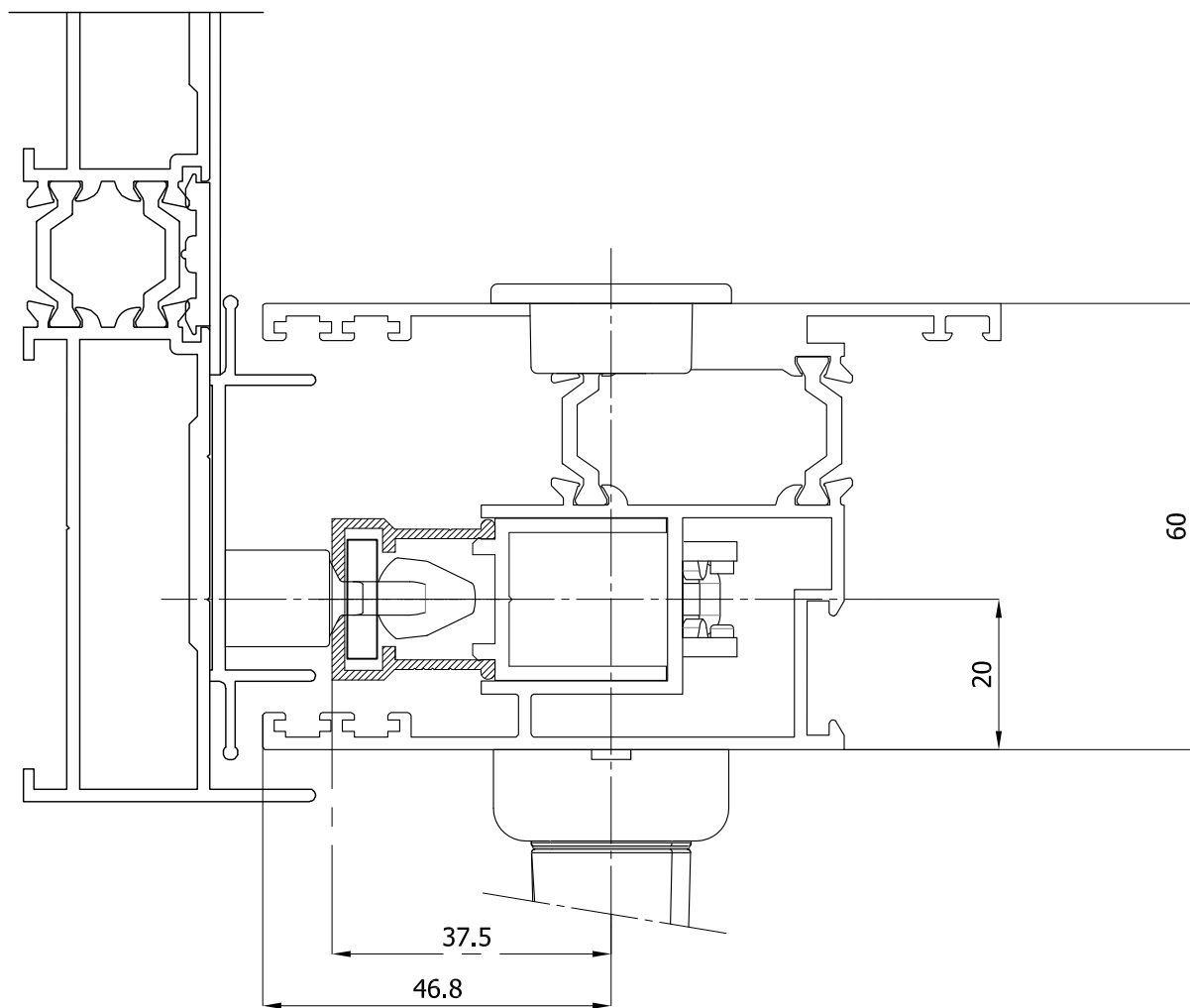
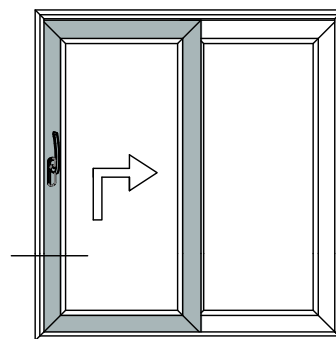

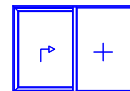

Etem E3000

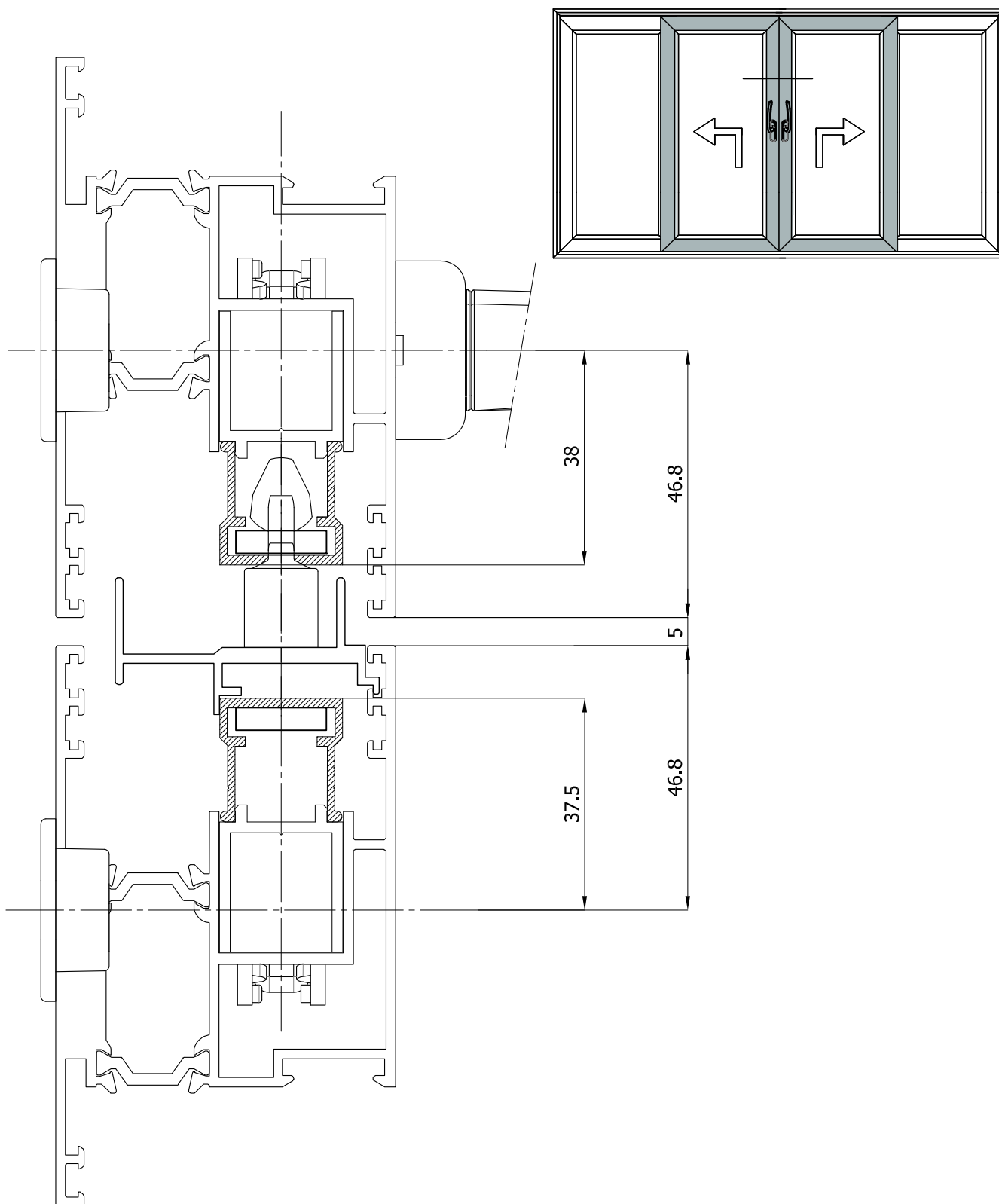

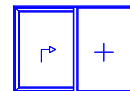

Feal termo 120

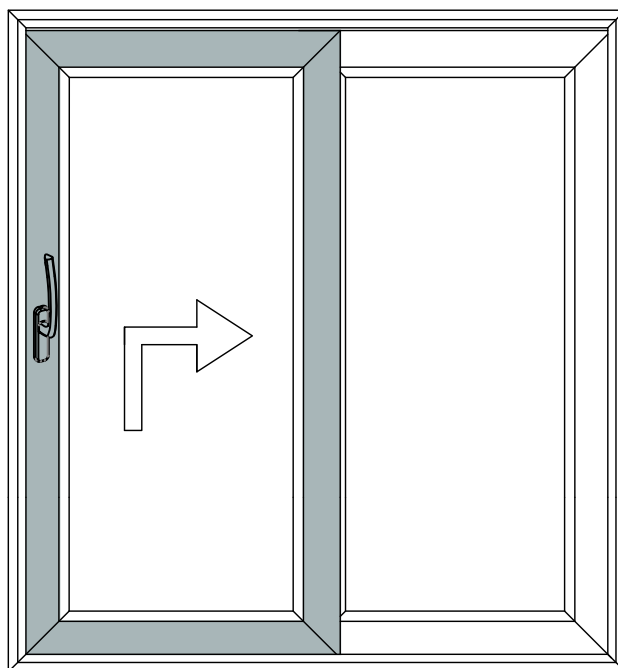
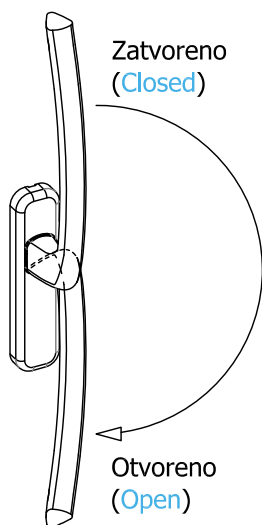

Raspored krila / Sash arrangement

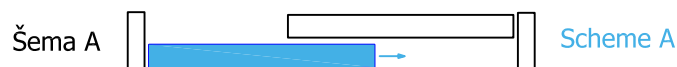

Tehnički podaci / Technical Data

Širina krila / Sash width 700 - 3250 mm
 Visina krila / Sash height 1150 - 2760 mm
 Spoljna širina okvira / Outer frame width 6500 mm

Nosivost krila / Sash weight max. 250 kg

Visina ručice / Handle position

Prozor / Window 407,5 mm
 Vrata / Door 1007,5 mm

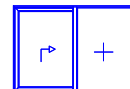

Feal termo 120

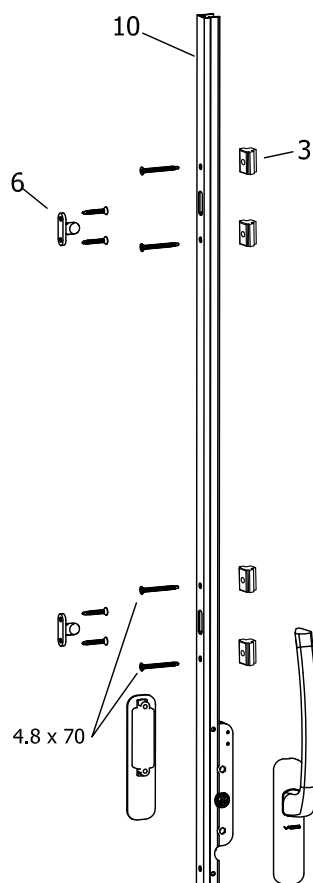

Klizno podizni sistem / Lift and slide system									
Poz. / Pos.	Naziv elementa / Name	Šifra / Code	Šifra naručivanja / Order code	Sema / Scheme					
				A	D	C	F		
1	Prednja kolica / Front rollers	92520	set 94250	1	1	1	2		
2	Zadnja kolica / Back rollers	92620							
3	Podmetač profila brave / Cover for door lock	92070							
4	Podmetač kolica bočni / Plastic cover side	92085							
5	Graničnik / Limiter	94020							
6	Zabavljivač / Lock	92762							
7	Oslonac kolica - prednji / Bogie support	94110							
8	Oslonac kolica - zadnji / Bogie support	94115							
9	Spojka kolica / Rollers connector	DK / FB	Dužina spojke / Length rollers connector	1	2	2	4		
		700-1500	750					92305	92305
		1501-1750	1000					92310	92310
		1751-2250	1500					92315	92315
		2251-2750	2000					92320	92320
10	Profil brave / Door lock profil	VK / FH	Dužina brave / Length door lock	1	2	2	4		
		1150-1760	1700					92205	92205
		1830-2260	2200					92245	92245
		2080-2760	2700					92285	92285
11	Pomoćna kolica (za težine krila preko 250 kg) / Assistance rollers (for weight > 250 kg)	92660	92660						

Klizno podizni sistem / Lift and slide						set 94250	set 94252	set 94254	set 94256
Poz. / Pos.	Naziv elementa / Name	Šifra / Code	Kom. / Pes.	Kom. / Pes.	Kom. / Pes.	Kom. / Pes.	Kom. / Pes.	Kom. / Pes.	
1	Prednja kolica / Front rollers	92520	1	1	1	1	1	1	
2	Zadnja kolica / Back rollers	92620	1	1	1	1	1	1	
3	Podmetač profila brave / Cover for door lock	92070	6	6	6	6	6	6	
4	Podmetač kolica bočni / Plastic cover side	92085	1	1	1	1	1	1	
5	Graničnik / Limiter	94020	2	-	2	-	-	-	
6	Zabavljivač / Lock	92762	3	3	-	-	-	-	
7	Oslonac kolica - prednji / Bogie support	94110	1	1	1	1	1	1	
8	Oslonac kolica - zadnji / Bogie support	94115	2	2	2	2	2	2	

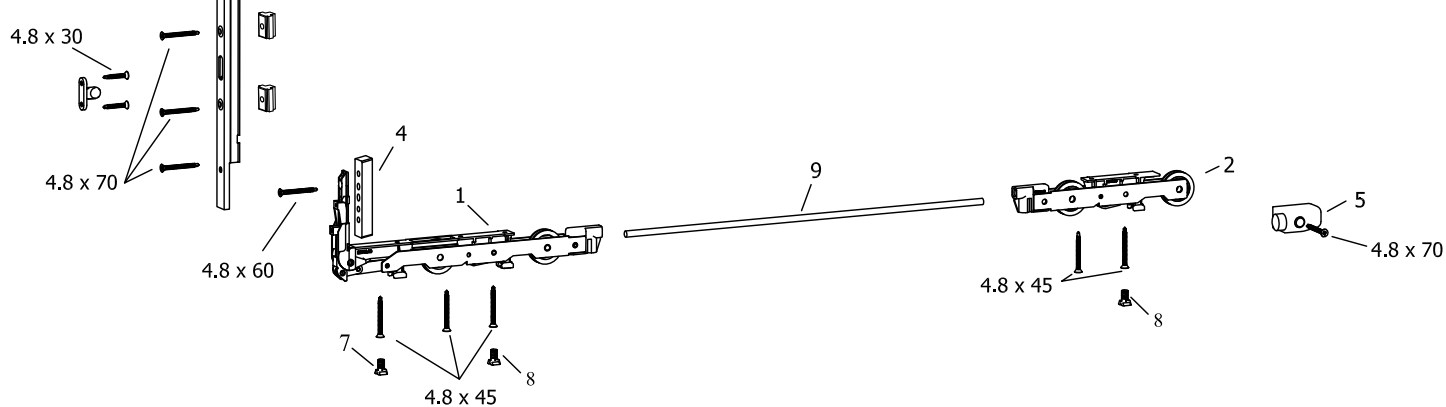

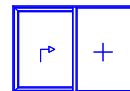

Feal termo 120

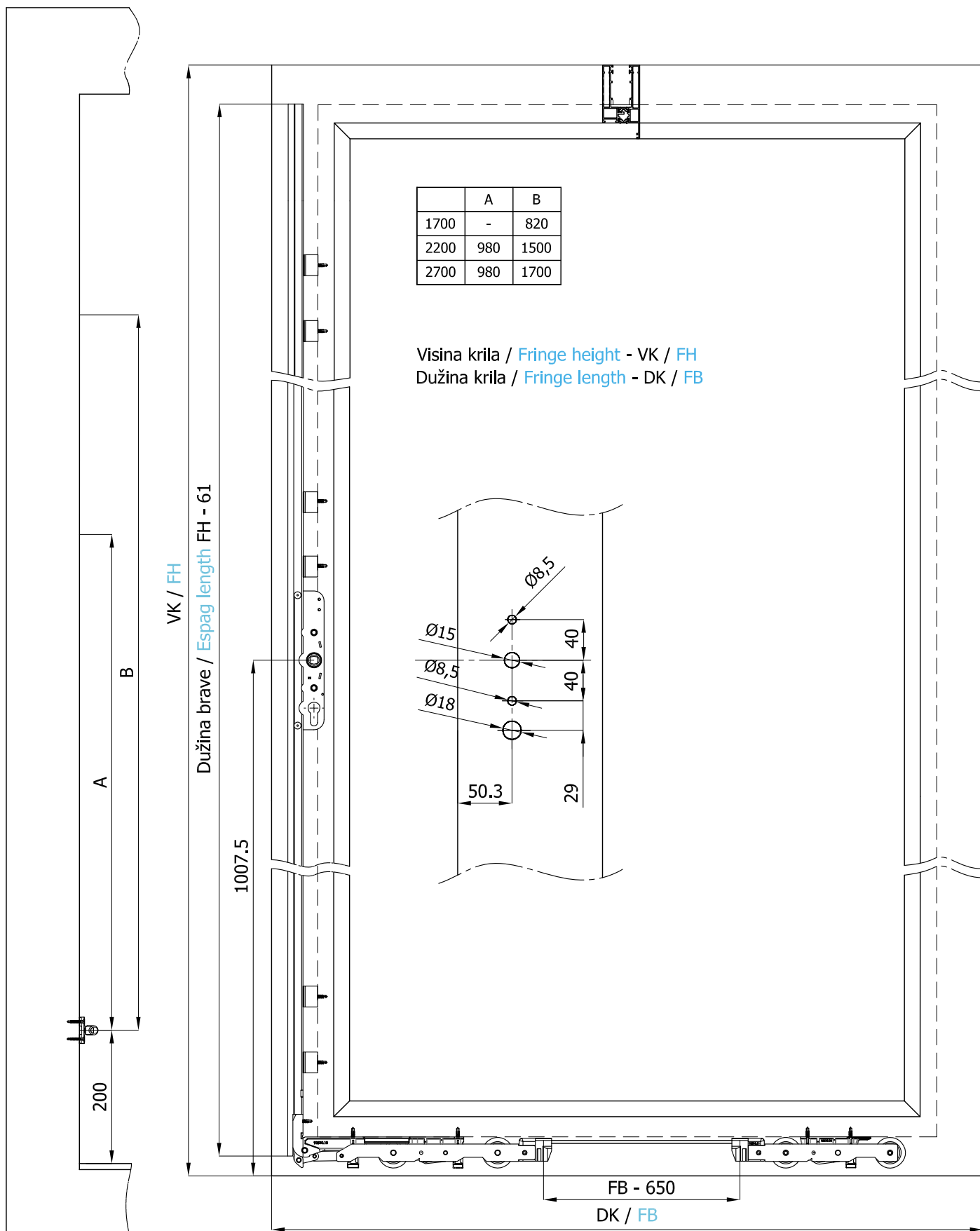

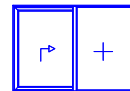

Feal termo 120

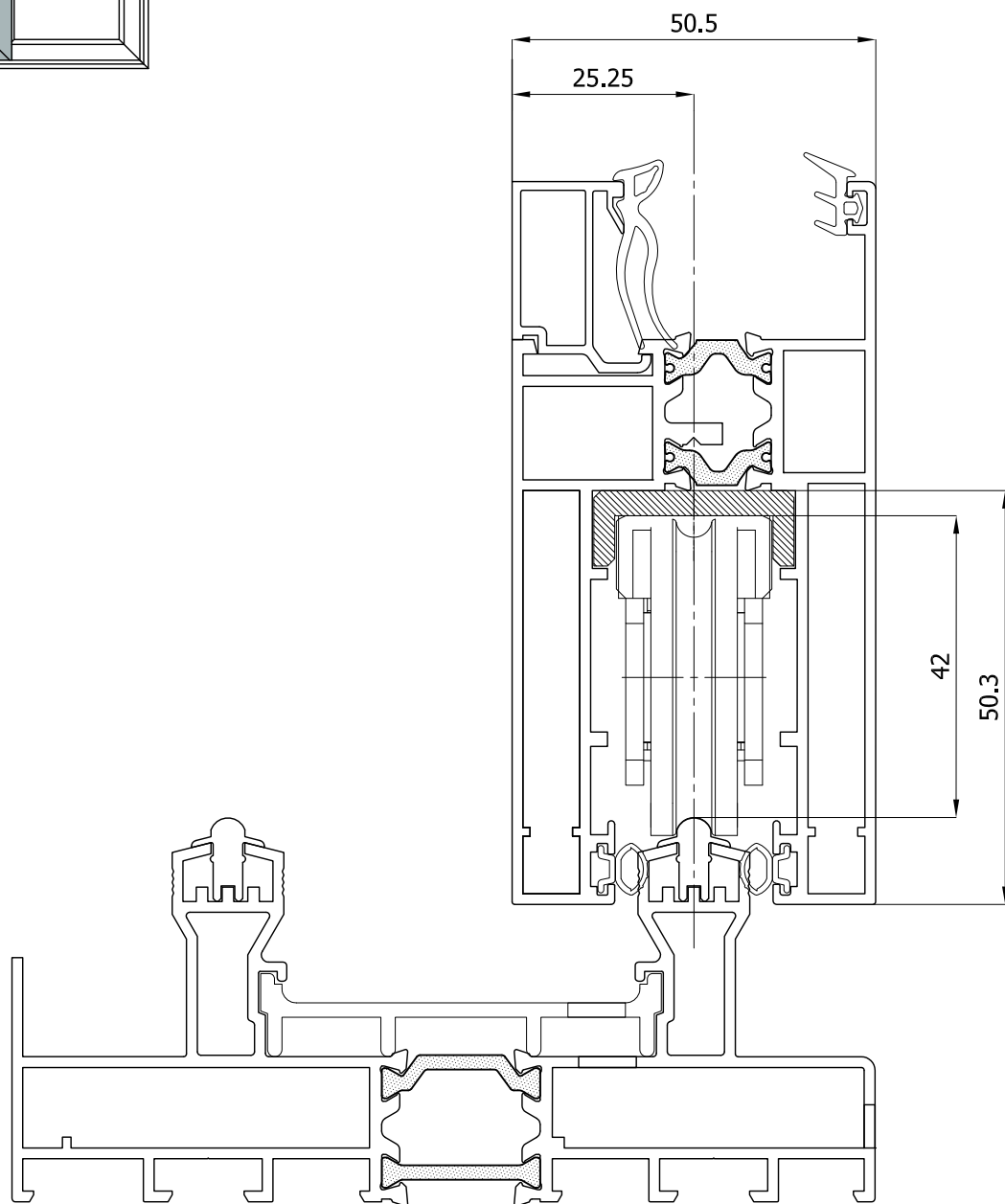
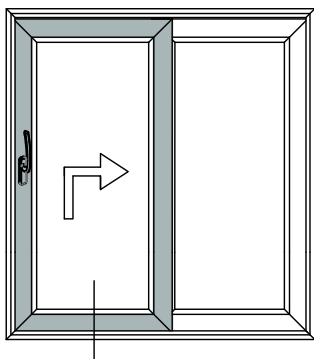

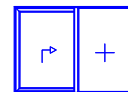

Feal termo 120

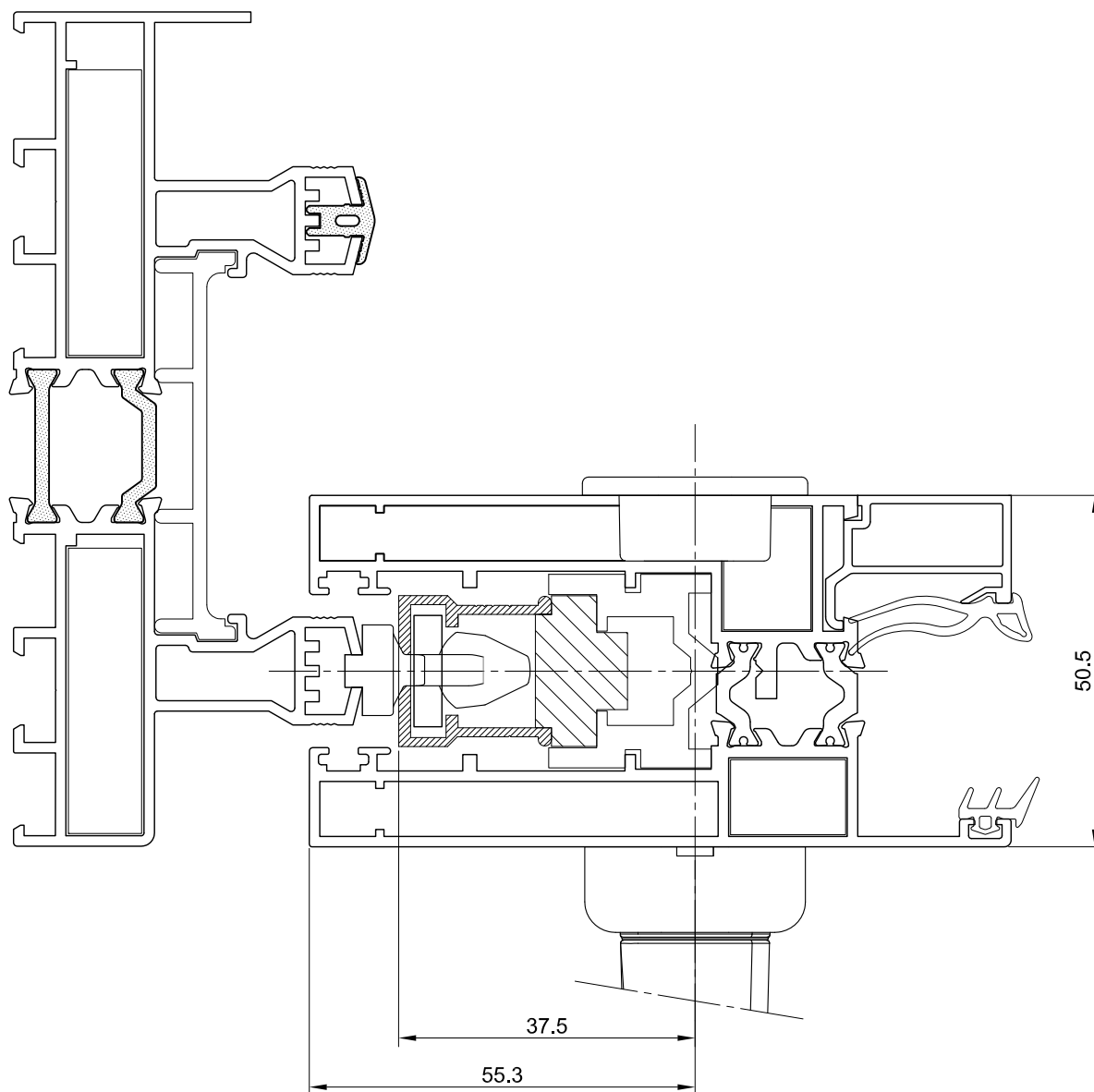
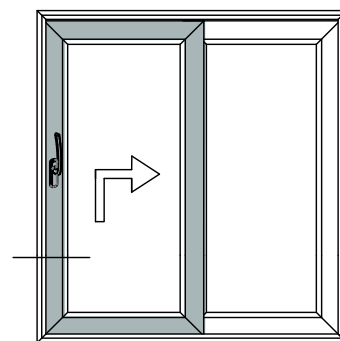

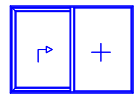

Feal termo 120

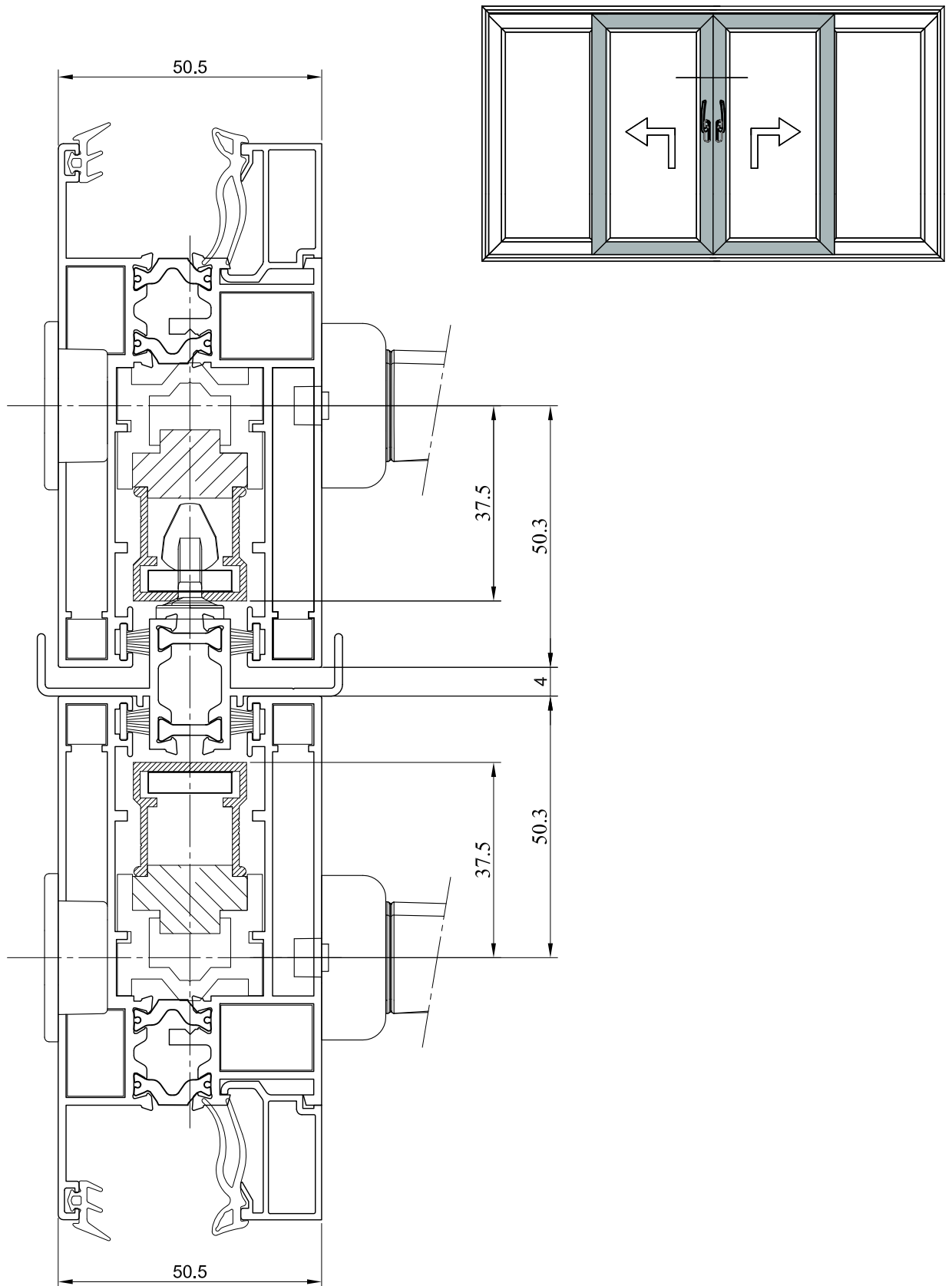

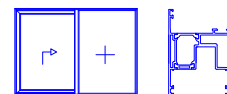

Schuco ass 70

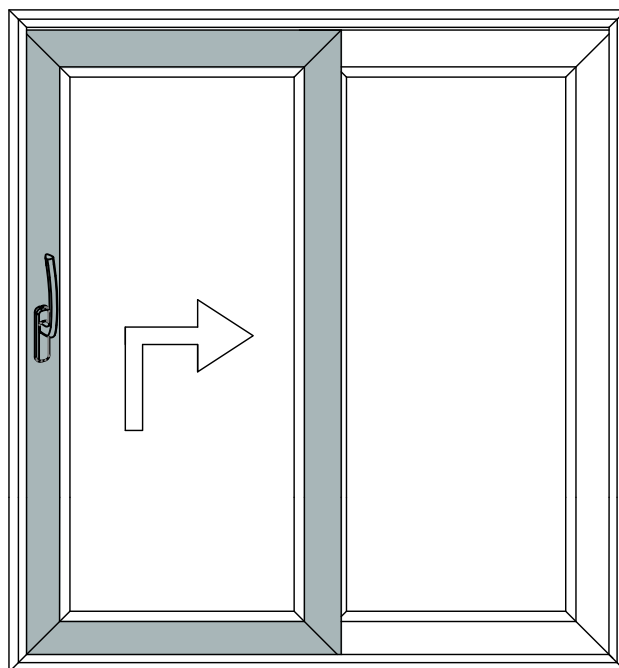
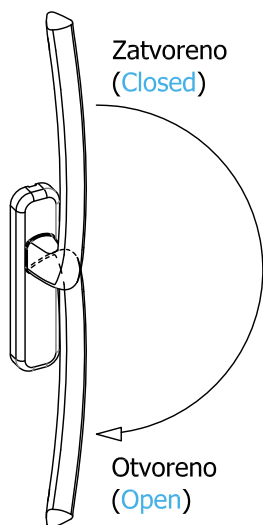

Raspored krila / Sash arrangement

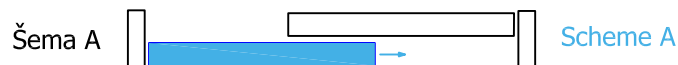

Tehnički podaci / Technical Data

Širina krila / Sash width 700 - 3250 mm
 Visina krila / Sash height 1150 - 2760 mm
 Spoljna širina okvira / Outer frame width 6500 mm

Nosivost krila / Sash weight max. 250 kg

Visina ručice / Handle position

Prozor / Window 408 mm

Vrata / Door 1008,5 mm

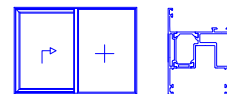

Schuco ass 70

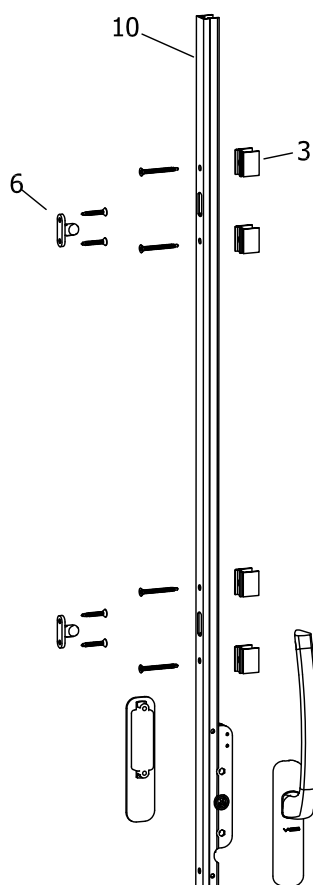

Klizno podizni sistem / Lift and slide system									
Poz. / Pos.	Naziv elementa / Name	Šifra / Code	Šifra naručivanja / Order code	Sema / Scheme					
				A	D	C	F		
1	Prednja kolica / Front rollers	92510	set 94260	1	1	1	2		
2	Zadnja kolica / Back rollers	92610							
3	Podmetač profila brave / Cover for door lock	92079						set 94262	
4	Podmetač kolica bočni / Plastic cover side	92089						set 94264	
5	Graničnik / Limiter	94020						set 94266	
6	Zabavljivač / Lock	92765							
7	Oslonac kolica - prednji / Bogie support	94110							
8	Oslonac kolica - zadnji / Bogie support	94115							
9	Spojka kolica / Rollers connector	DK / FB	Dužina spojke / Length rollers connector	1	2	2	4		
		700-1500	750					92305	92305
		1501-1750	1000					92310	92310
		1751-2250	1500					92315	92315
		2251-2750	2000					92320	92320
10	Profil brave / Door lock profil	VK / FH	Dužina brave / Length door lock	1	2	2	4		
		1150-1760	1700					92205	92205
		1830-2260	2200					92245	92245
		2080-2760	2700					92285	92285
11	Pomoćna kolica (za težine krila preko 250 kg) / Assistance rollers (for weight > 250 kg)	92650	92650						

Klizno podizni sistem / Lift and slide						set 94260	set 94262	set 94264	set 94266
Poz. / Pos.	Naziv elementa / Name	Šifra / Code	Kom. / Pes.	Kom. / Pes.	Kom. / Pes.	Kom. / Pes.	Kom. / Pes.	Kom. / Pes.	
1	Prednja kolica / Front rollers	92510	1	1	1	1			
2	Zadnja kolica / Back rollers	92610	1	1	1	1			
3	Podmetač profila brave / Cover for door lock	92079	6	6	6	6			
4	Podmetač kolica bočni / Plastic cover side	92089	1	1	1	1			
5	Graničnik / Limiter	94020	2	-	2	-			
6	Zabavljivač / Lock	92765	3	3	-	-			
7	Oslonac kolica - prednji / Bogie support	94110	1	1	1	1			
8	Oslonac kolica - zadnji / Bogie support	94115	2	2	2	2			

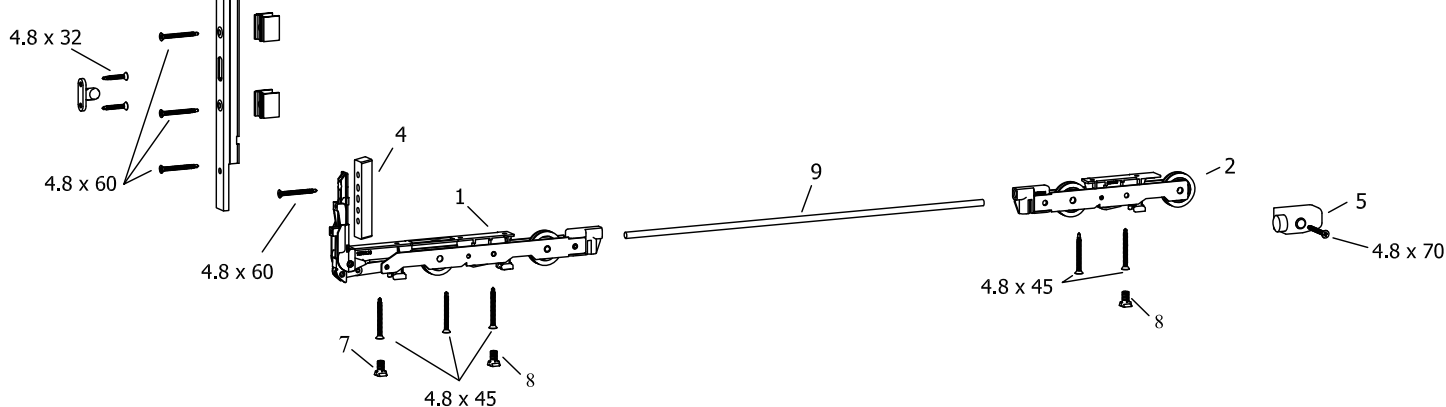

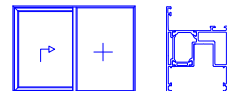

Schuco ass 70

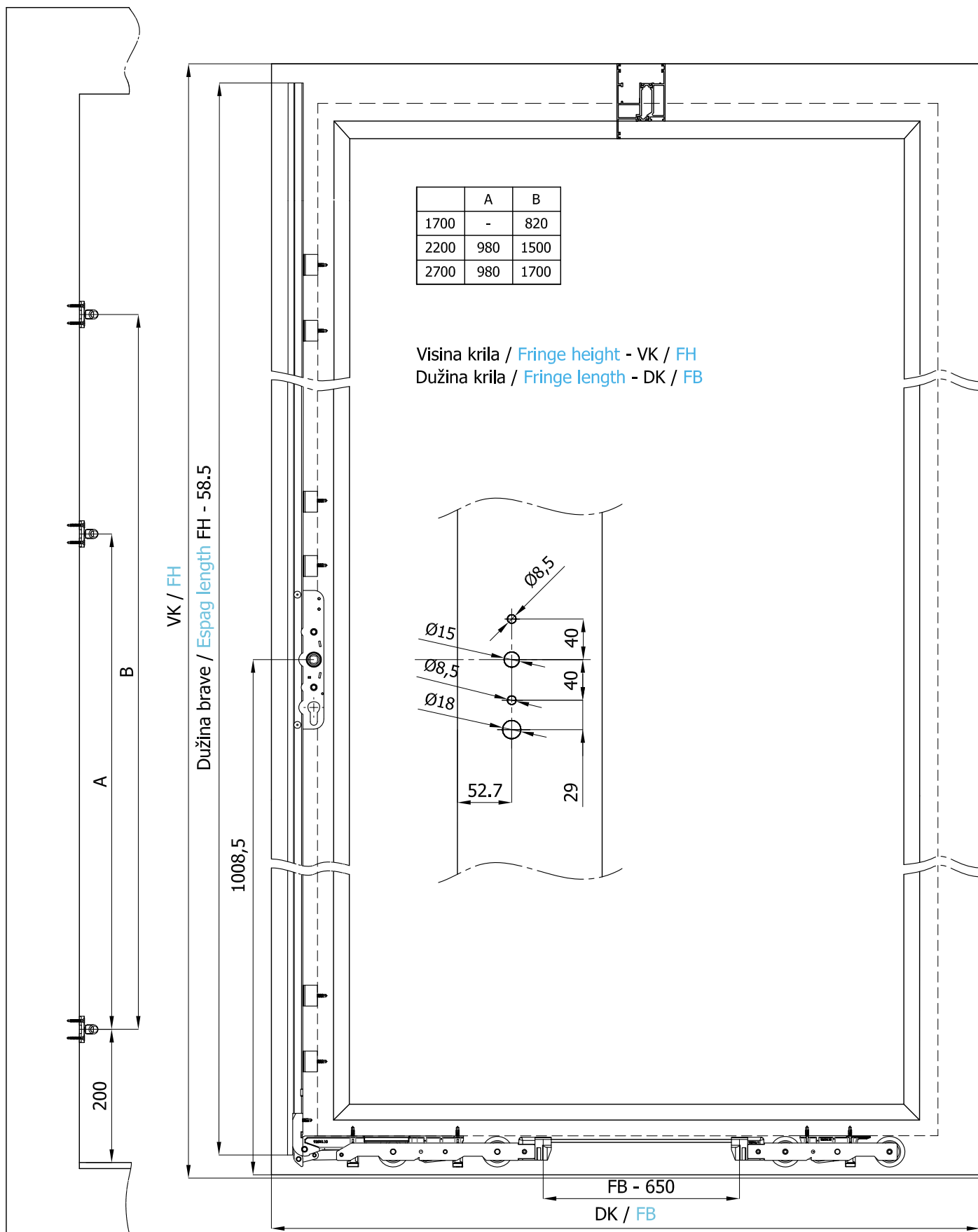

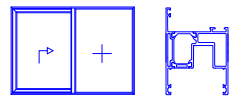

Schuco ass 70

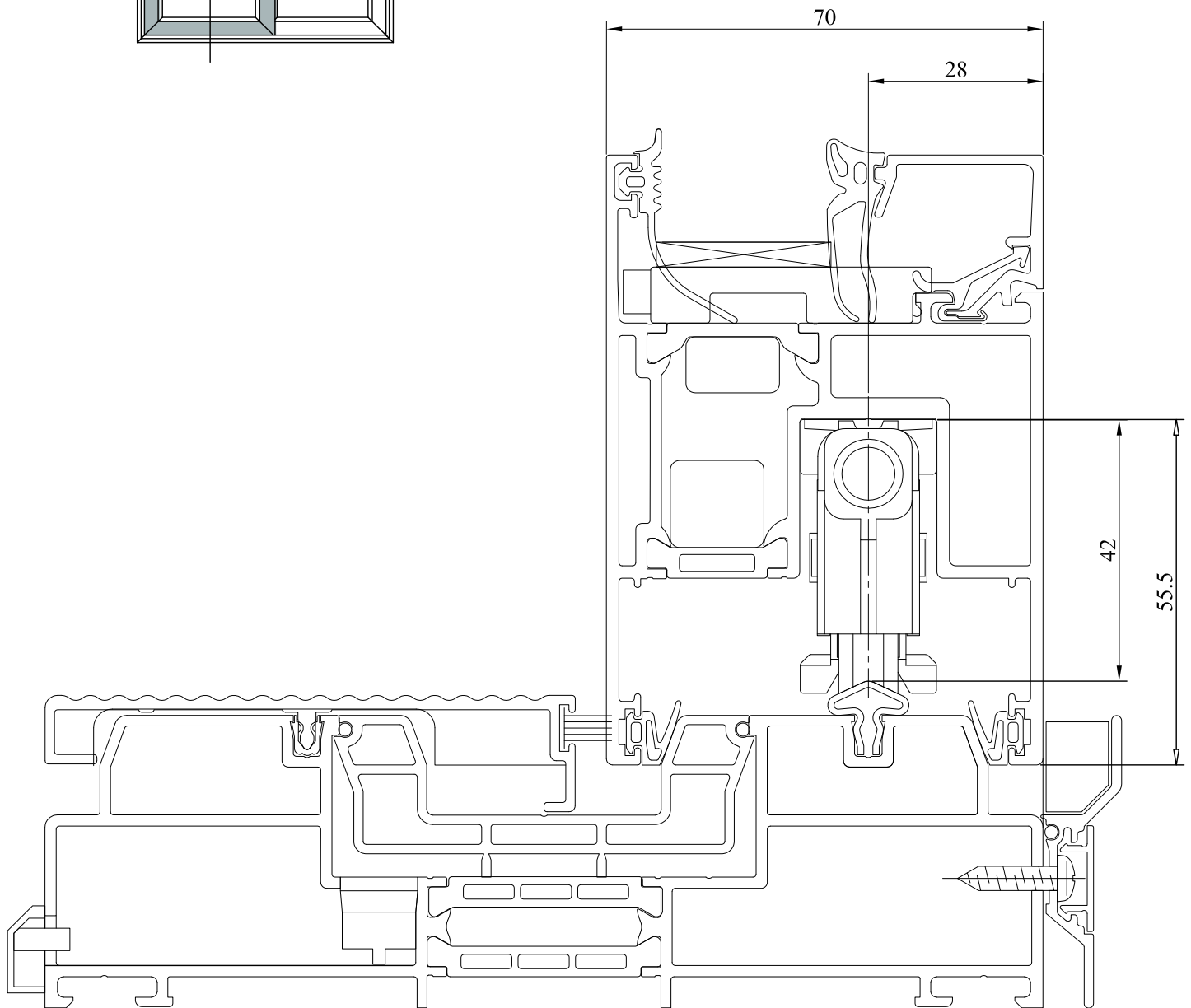
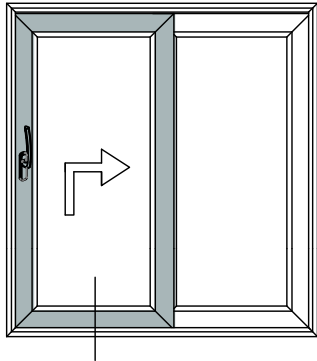

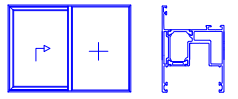

Schuco ass 70

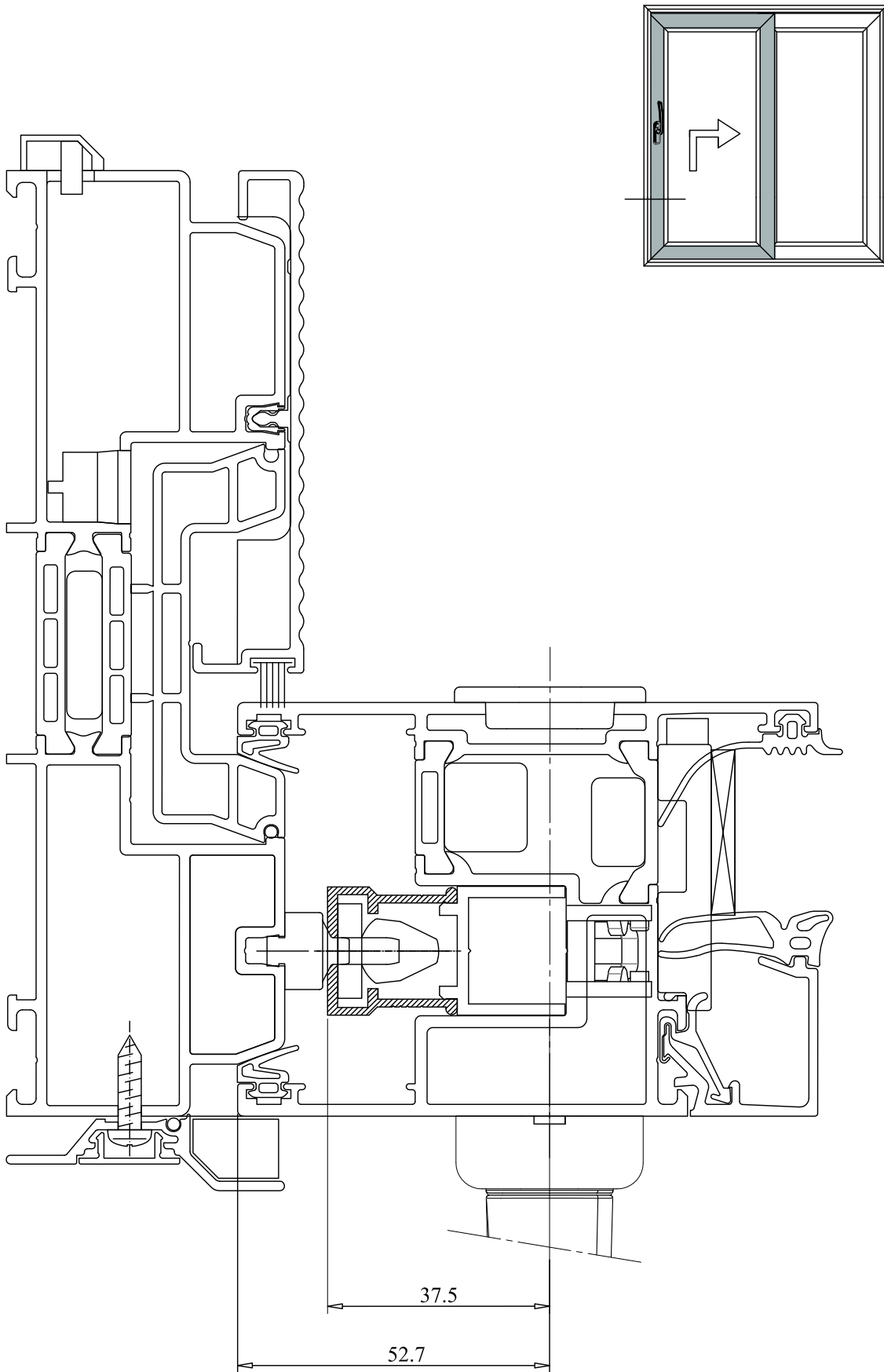

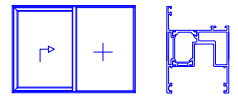

Schuco ass 70

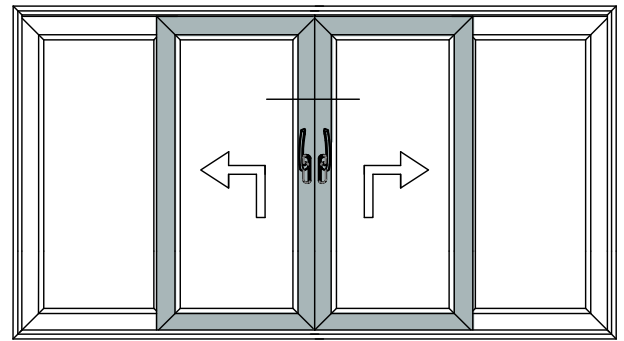
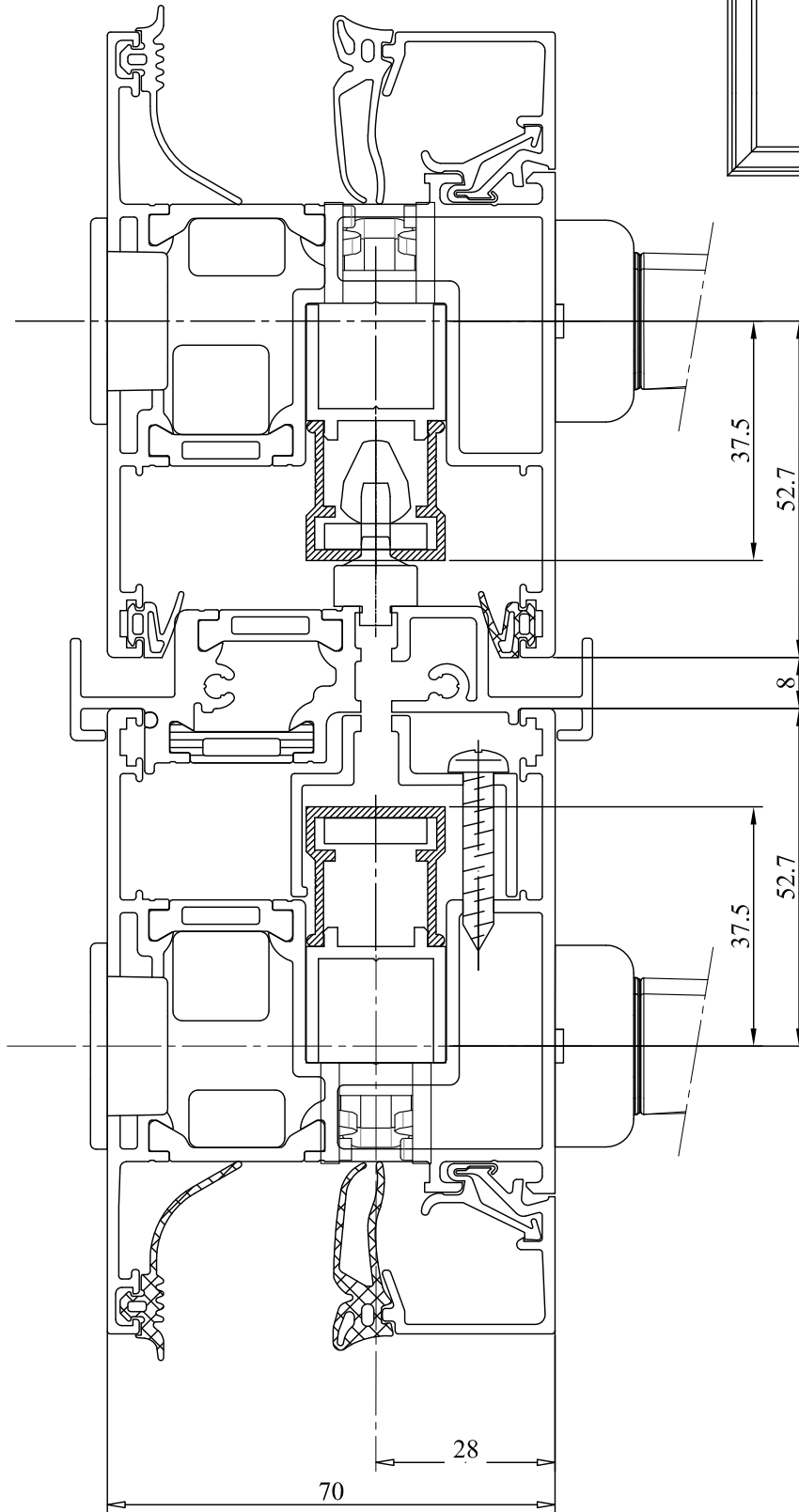

KLIZNO PODIZNI SISTEM

LIFT AND SLIDE

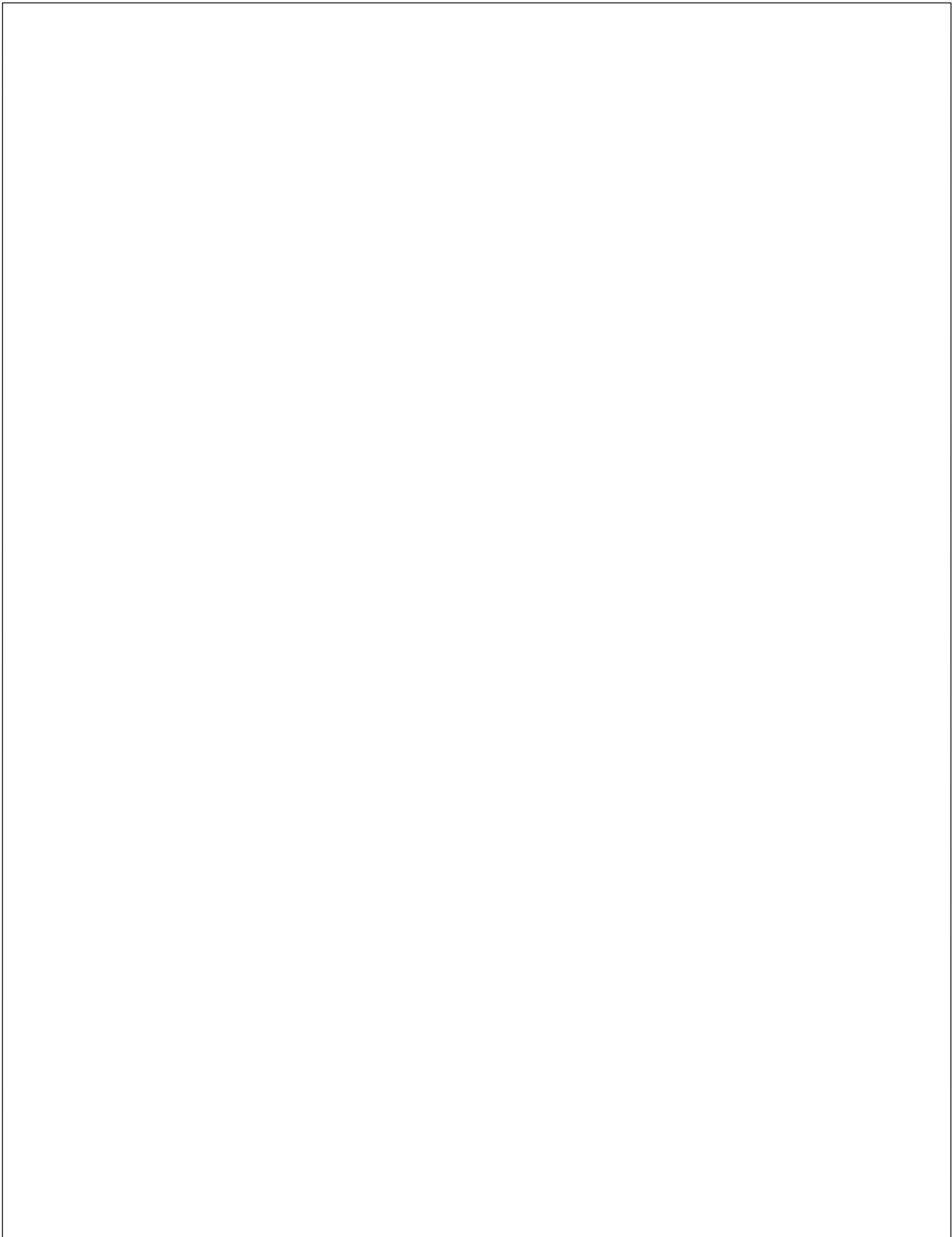

*Klizno podizni sistem za
PVC 250kg*

*Lift and slide system for
PVC 250kg*

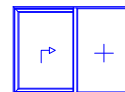

Gealan 8000

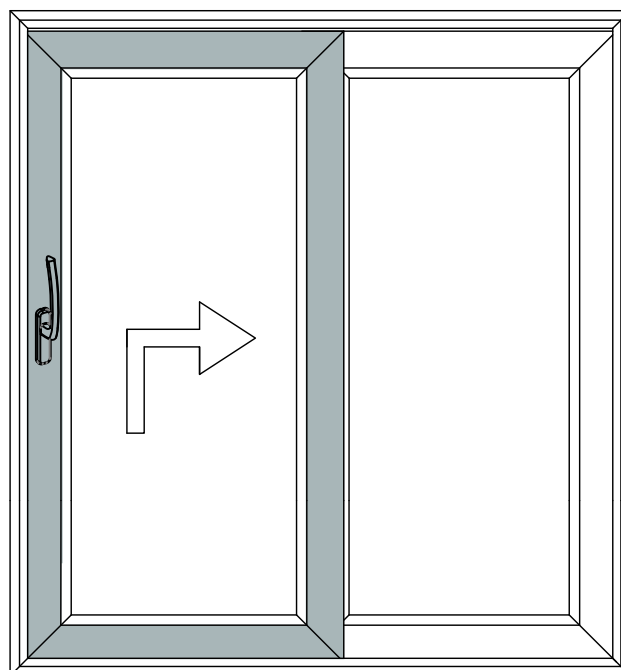
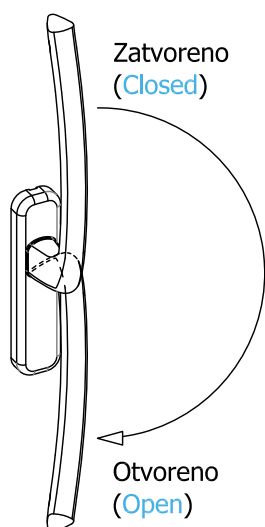

Sash arrangement

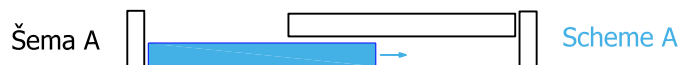

Tehnički podaci / Technical Data

Širina krila / Sash width 700 - 3250 mm

Visina krila / Sash height 1150 - 2760 mm

Spoljna širina okvira / Outer frame width 6500 mm

Nosivost krila / Sash weight max. 250 kg

Visina ručice / Handle position

Prozor / Window 400 mm

Vrata / Door 1000 mm

KLIZNO PODIZNI SISTEM -PVC

SISTEM - PRAG IZMEDJU STOKA

PVC - 250

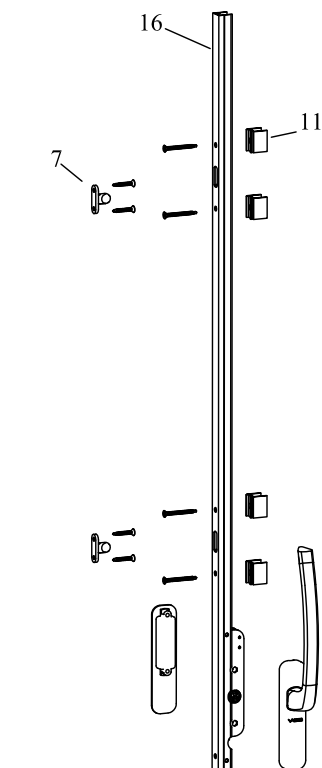
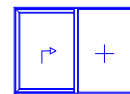

Klizno podizni sistem / Lift and slide system							set 94405	set 94407	
Poz. Pos.	Naziv elementa / Name	Šifra / Code	Šifra naručivanja / Order code	Šema / Scheme	A	C	K	Kom. Pes.	Kom. Pes.
1	Prednja kolica / Front rollers	92520	set 94405	1	1	1	1	1	1
2	Zadnja kolica / Back rollers	92620						1	1
3	Podmetač profila brave / Cover for door lock	92059						3	3
4	Podmetač kolica bočni / Plastic cover side	92088						1	1
5	Ugaoni distancer / Corner spacer	92095						2	2
6	Klizač gornje šine / Slider for top rail	92090						2	2
7	Zabavljiivač / Lock	92751						3	-
8	PVC poklopac / PVC cover	92094						1	1
9	Poklopac - sunder guma / Cover - sponge rubber	92901						4	-
10	Podmetač - sunder guma / Pad - sponge rubber	92902						1	1
11	Podmetač brave / Cover for door lock	92059						6	6
12	Graničnik / Limiter	94020						2	2
13	Oslonac kolica - prednji / Bogie support	94110						1	1
14	Oslonac kolica - zadnji / Bogie support	94115						2	2
15	Spojka kolica / Rollers connector	DK / FB	Dužina spojke / Length rollers connector		1	2	2		
		700-1500	750	92305				92305	
		1501-1750	1000	92310				92310	
		1751-2250	1500	92315				92315	
		2251-2750	2000	92320				92320	
16	Profil brave / Door lock profil	VK / FH	Dužina brave / Length door lock		1	2	2		
		1150-1760	1700	92205				92205	
		1830-2260	2200	92245				92245	
		2080-2760	2700	92285				92285	
17	Pomoćna kolica (za težine krila preko 250 kg) / Assistance rollers (for weight > 250 kg)	92660	92660						

18	Prag / Doorstep	L	3000	3500	4000	4500	5000	5500	6000	6500
		sifra/code	92812	92814	92816	92818	92820	92822	92824	92826
19	Gornja šina / Top rail	L	3000	3500	4000	4500	5000	5500	6000	6500
		sifra/code	92852	92854	92856	92858	92850	92862	92864	92866
20	Podmetač praga / Pad for doorstep	L	2000	3500	6500					
		sifra/code	92872	92874	92876					

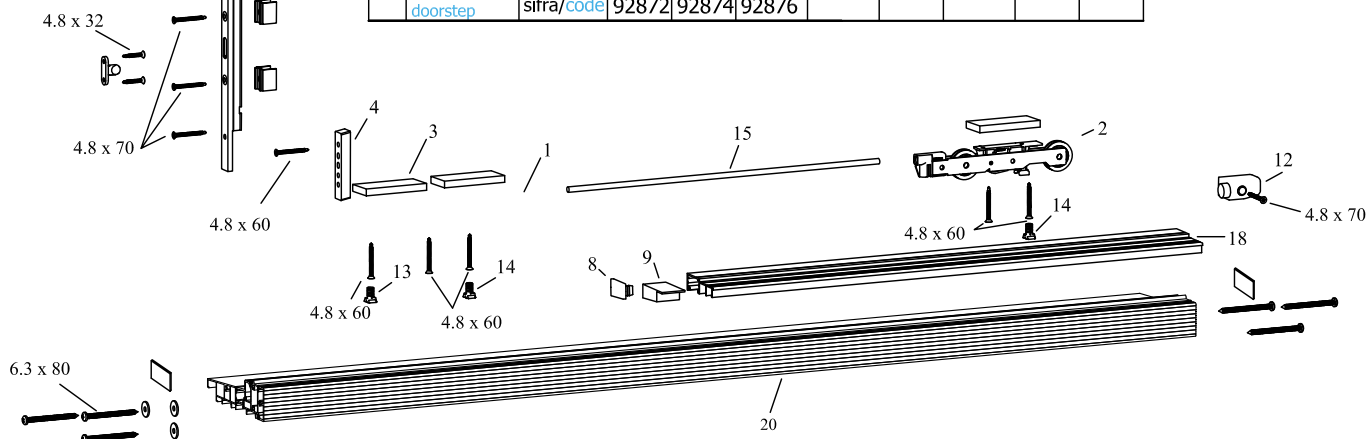

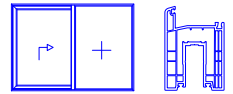

Gealan 8000

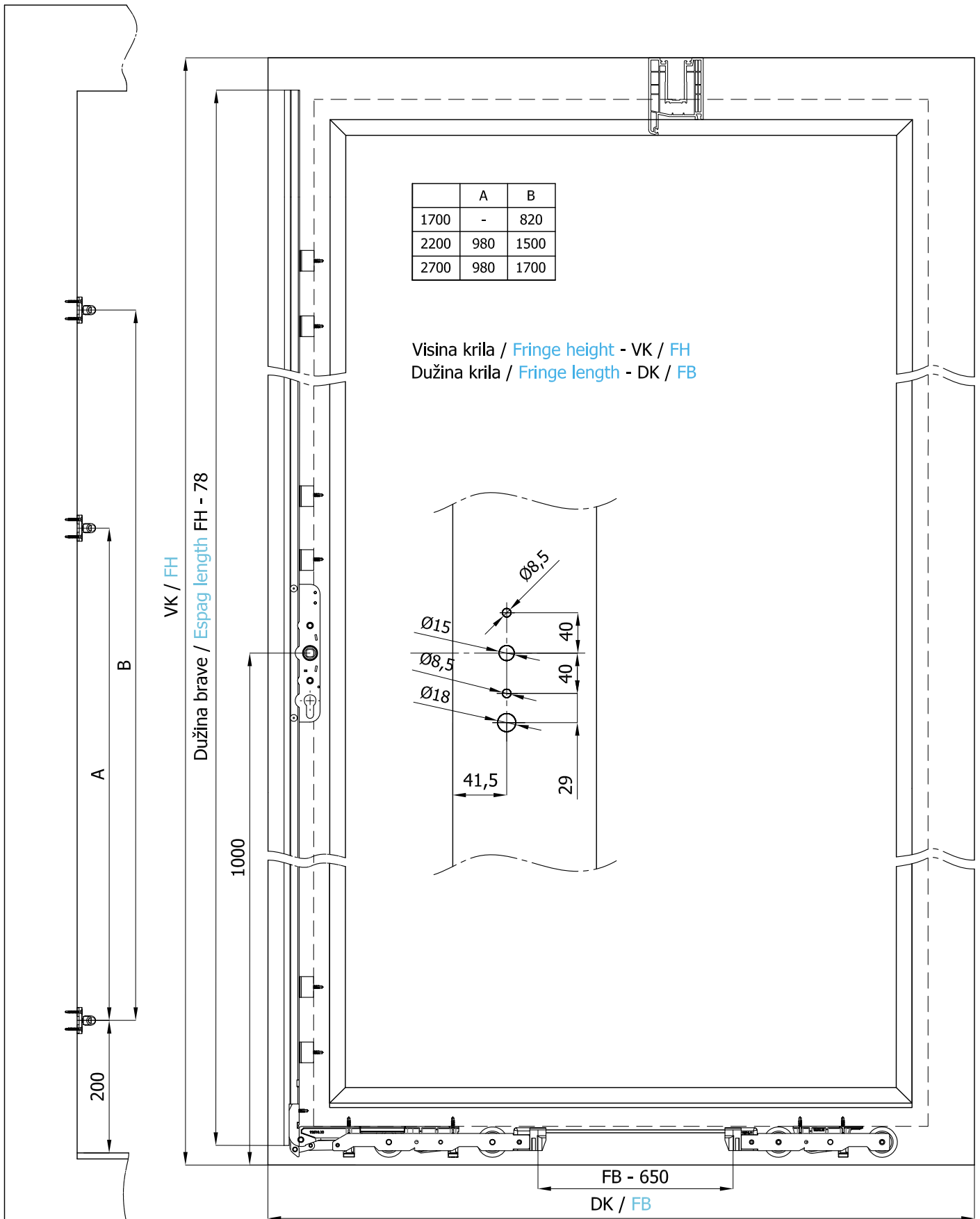

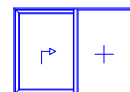

Gealan 8000

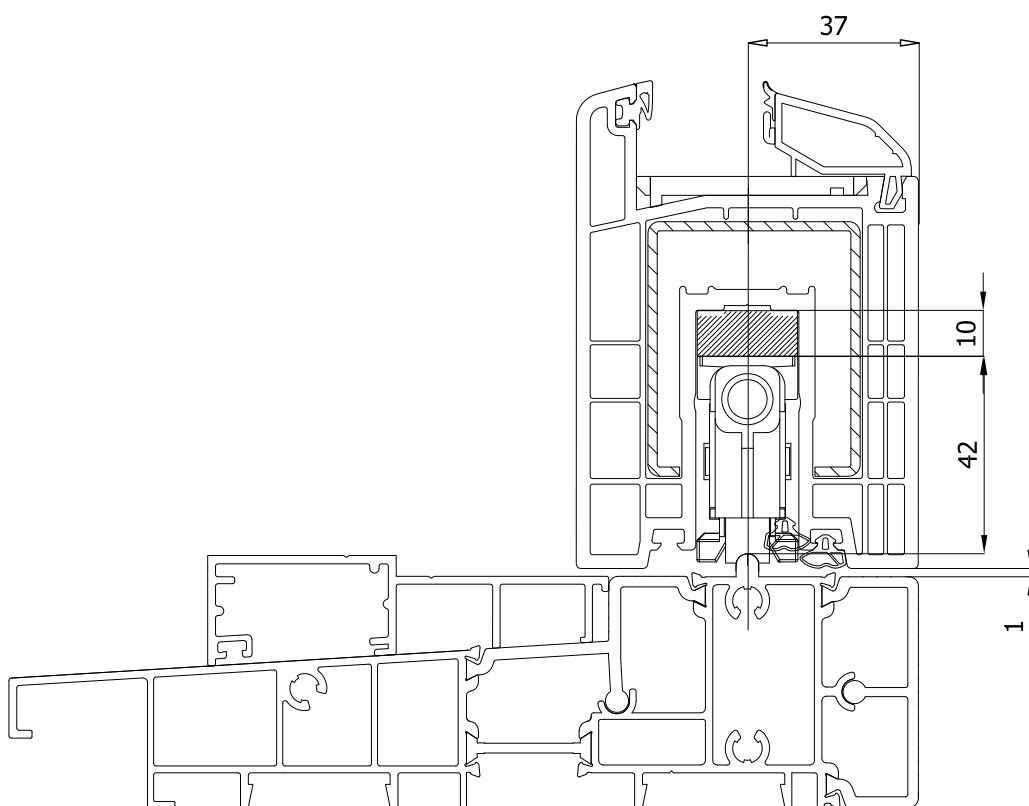
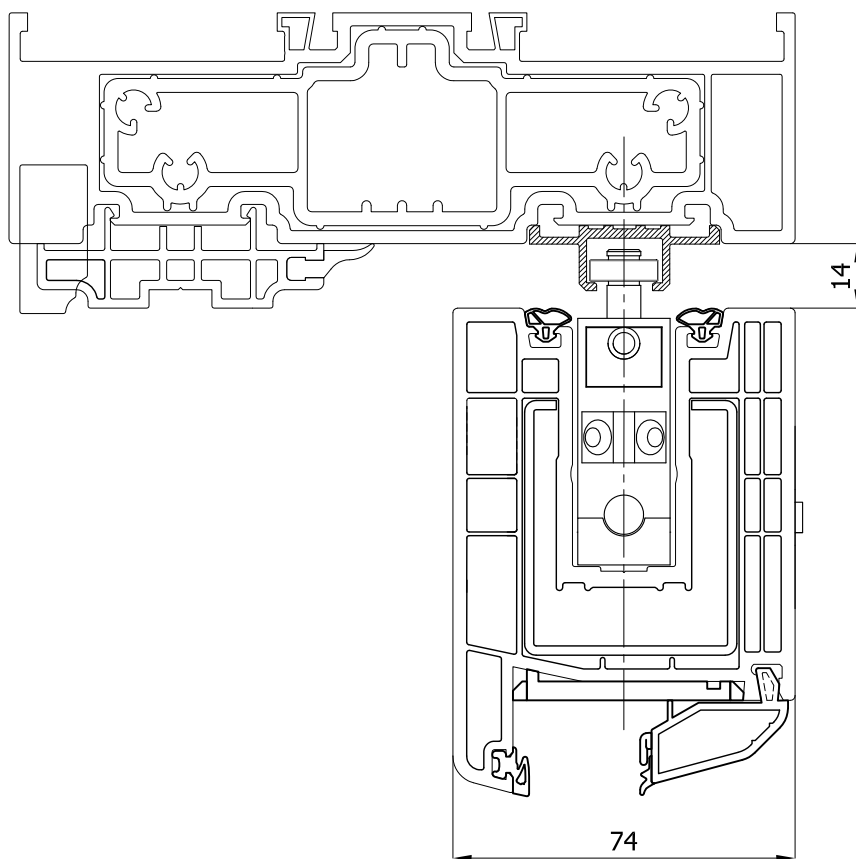
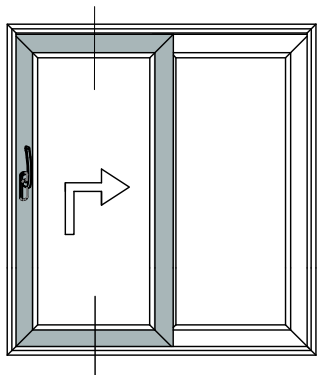

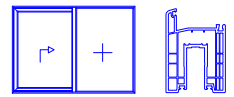

Gealan 8000

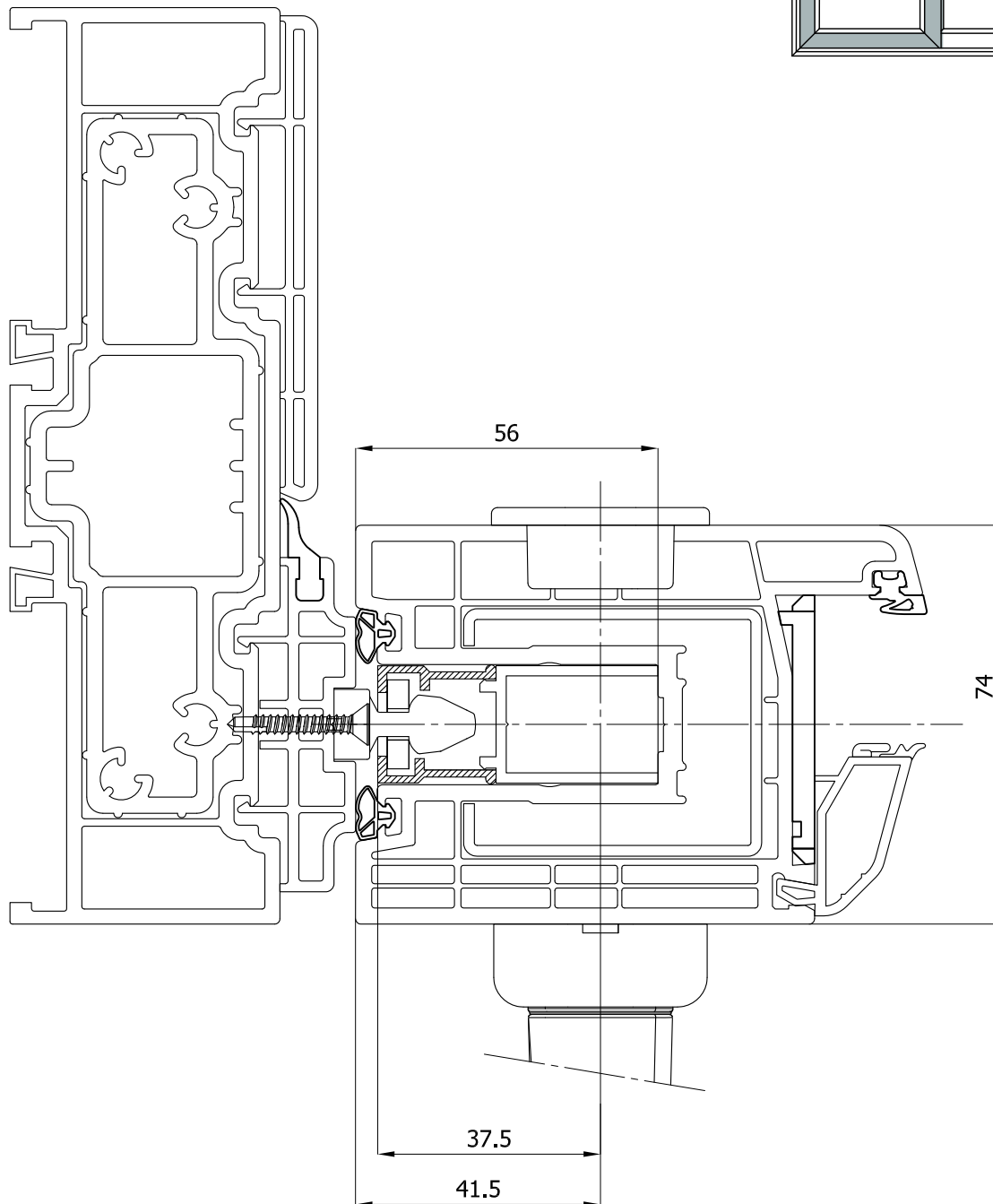
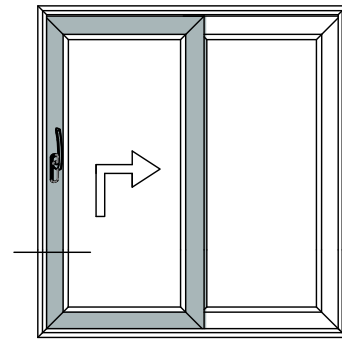

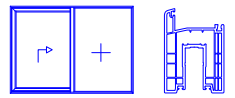

Gealan 8000

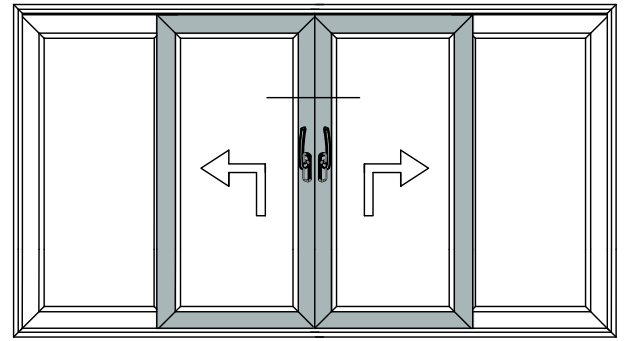
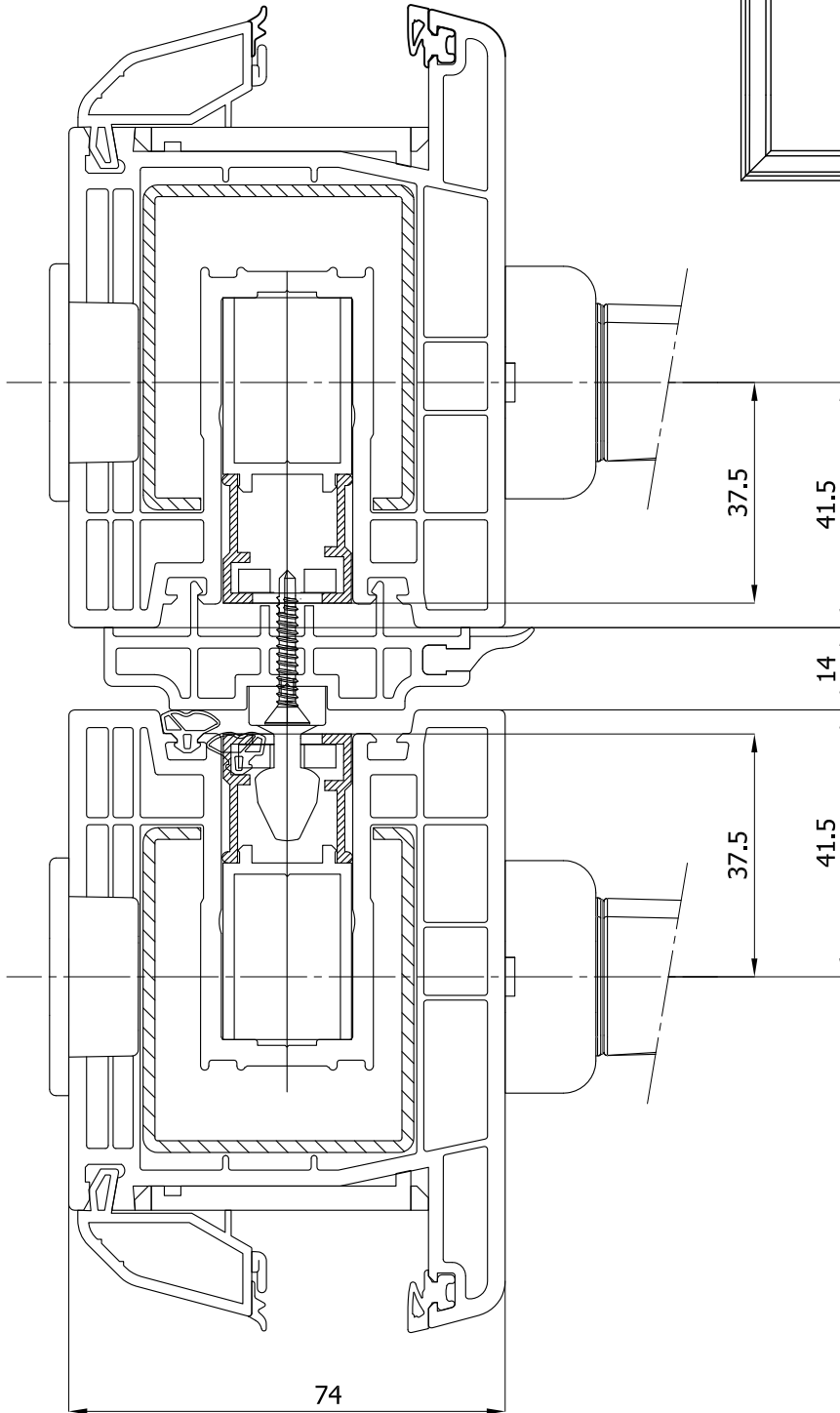

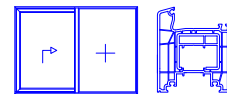

Aluplast 85

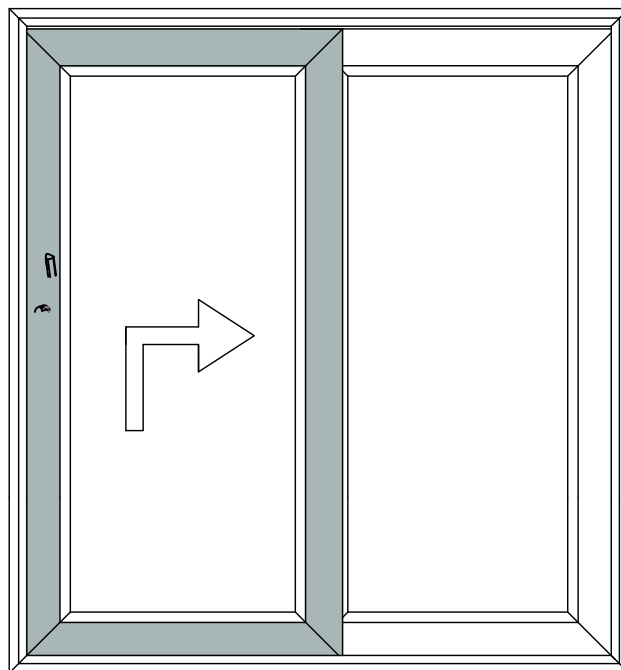
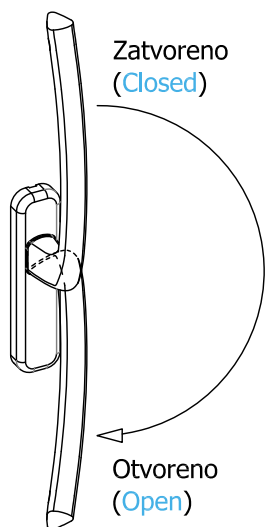

Sash arrangement

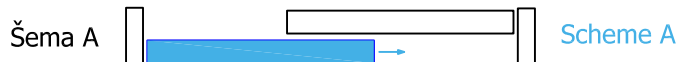

Tehnički podaci / Technical Data

Širina krila / Sash width 700 - 3250 mm

Visina krila / Sash height 1150 - 2760 mm

Spoljna širina okvira / Outer frame width 6500 mm

Nosivost krila / Sash weight max. 250 kg

Visina ručice / Handle position

Prozor / Window 408 mm

Vrata / Door 1008 mm

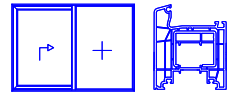

Aluplast 85

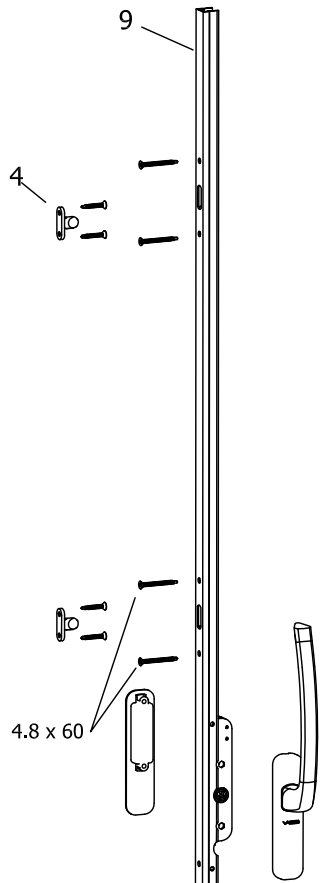

Klizno podizni sistem / Lift and slide system							set 94425	set 94427		
Poz. / Pos.	Naziv elementa / Name	Šifra / Code	Šifra naručivanja / Order code	Šema / Scheme			Kom. / Pes.	Kom. / Pes.		
				A	C	K				
1	Prednja kolica / Front rollers	92520	set 94425	1	1	2	1	1		
2	Zadnja kolica / Back rollers	92620					1	1		
3	Podmetač kolica bočni / Plastic cover side	92086					1	1		
4	Zabravljivač / Lock	92752	set 94427	1			3	-		
5	Graničnik / Limiter	94020					2	2		
6	Oslonac kolica - prednji / Bogie support	94110					1	1		
7	Oslonac kolica - zadnji / Bogie support	94115					2	2		
8	Spojka kolica / Rollers connector	DK / FB	Dužina spojke / Length rollers connector	1	2	2				
		700-1500	750						92305	92305
		1501-1750	1000						92310	92310
		1751-2250	1500						92315	92315
		2251-2750	2000						92320	92320
2751-3250	2500	92325	92325							
9	Profil brave / Door lock profil	VK / FH	Dužina brave / Length door lock	1	2	2				
		1150-1760	1700						92205	92205
		1830-2260	2200						92245	92245
		2080-2760	2700						92285	92285
10	Pomoćna kolica (za težine krila preko 250 kg) / Assistance rollers (for weight > 250 kg)	92660	92660							

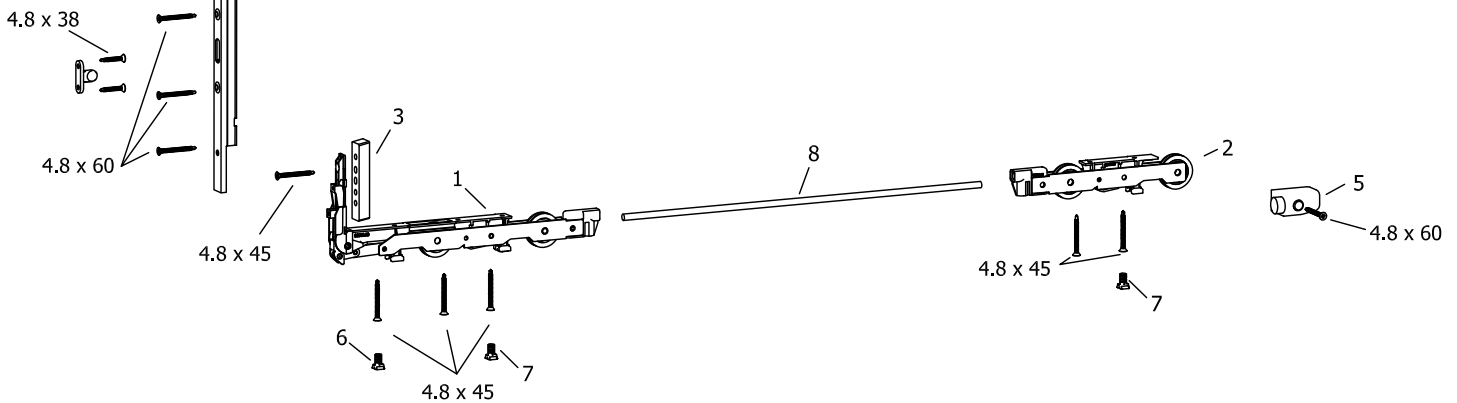

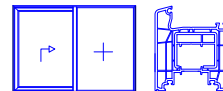

Aluplast 85

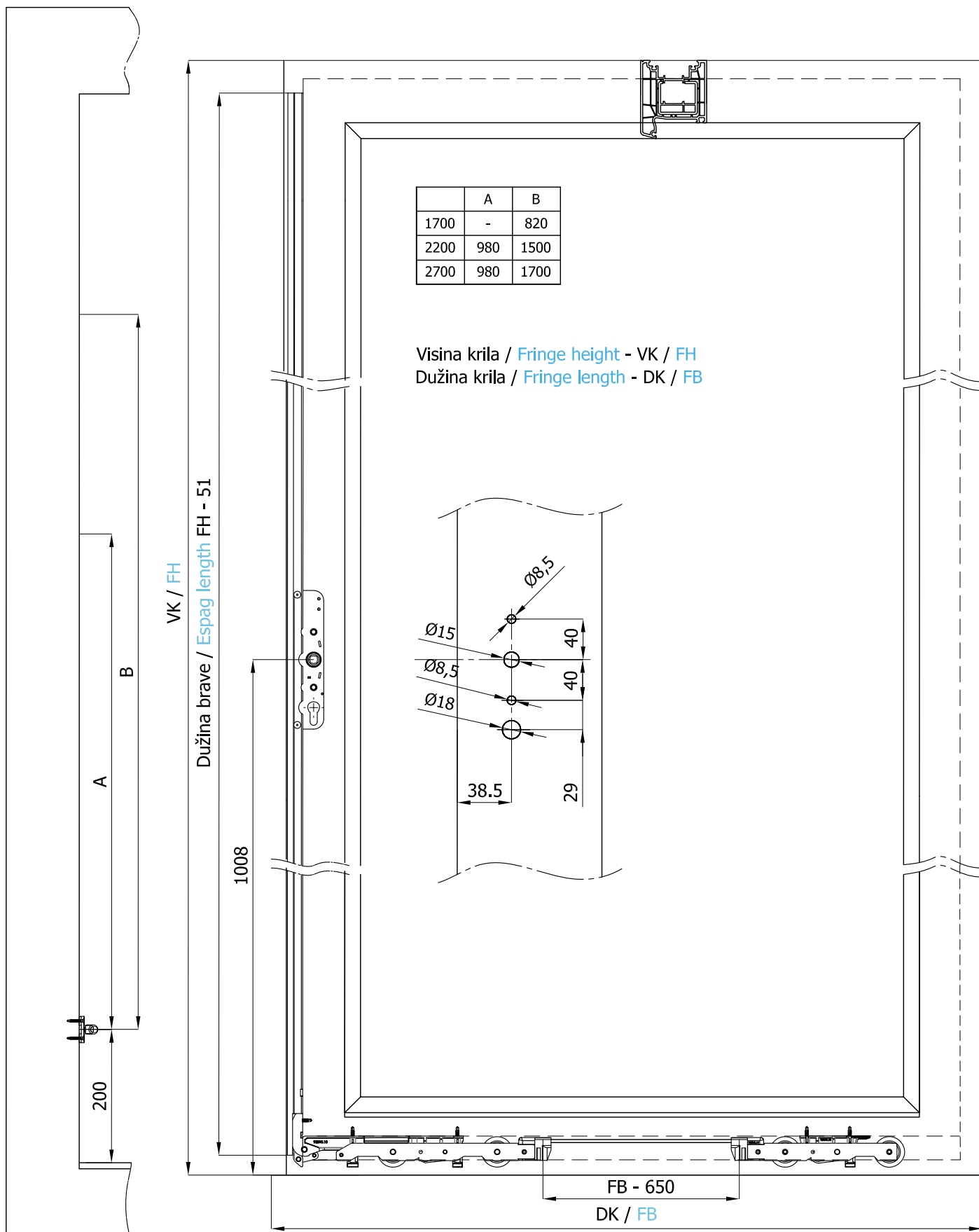

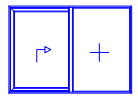

Aluplast 85

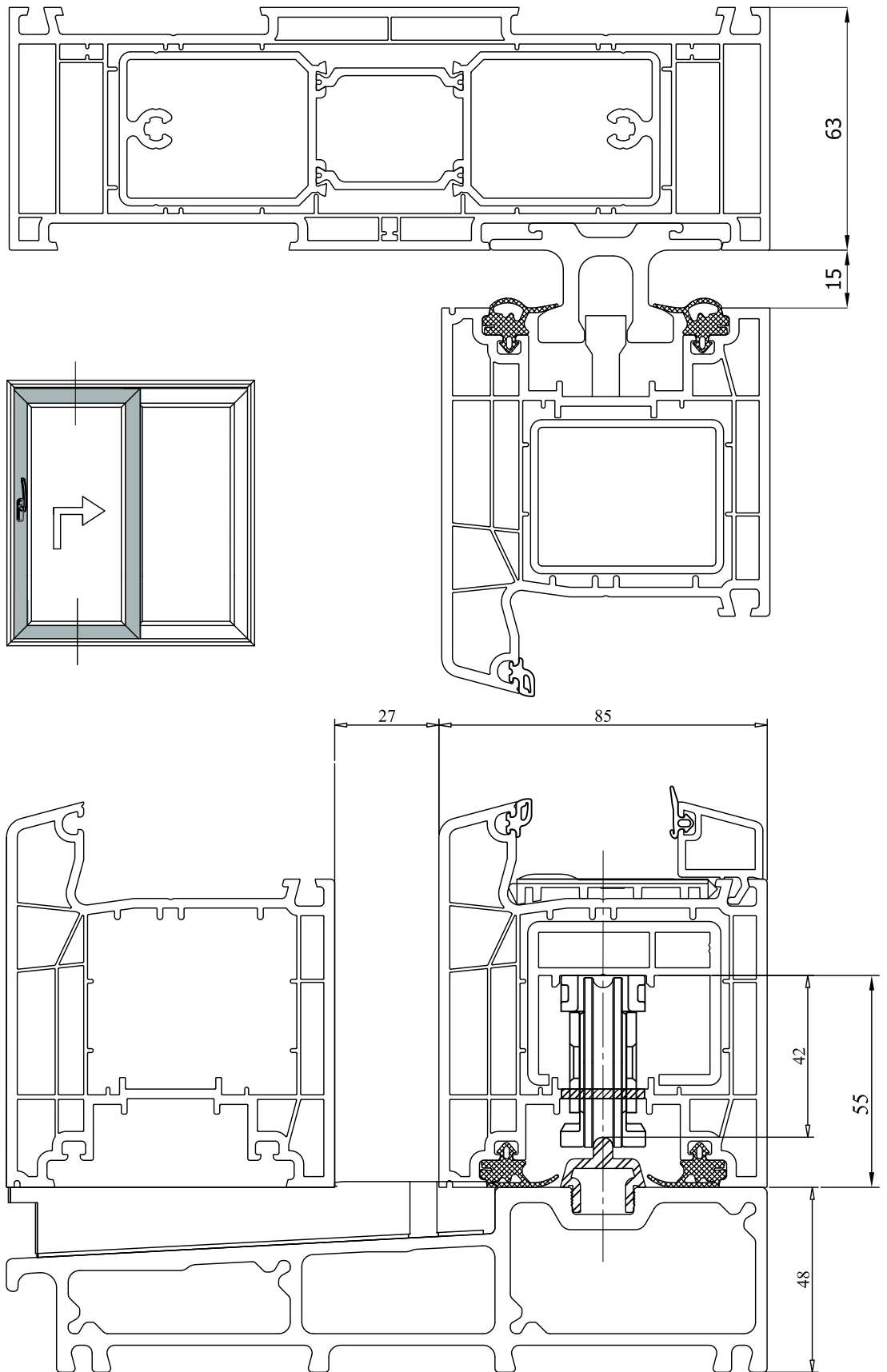

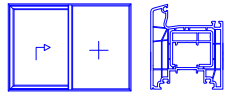

Aluplast 85

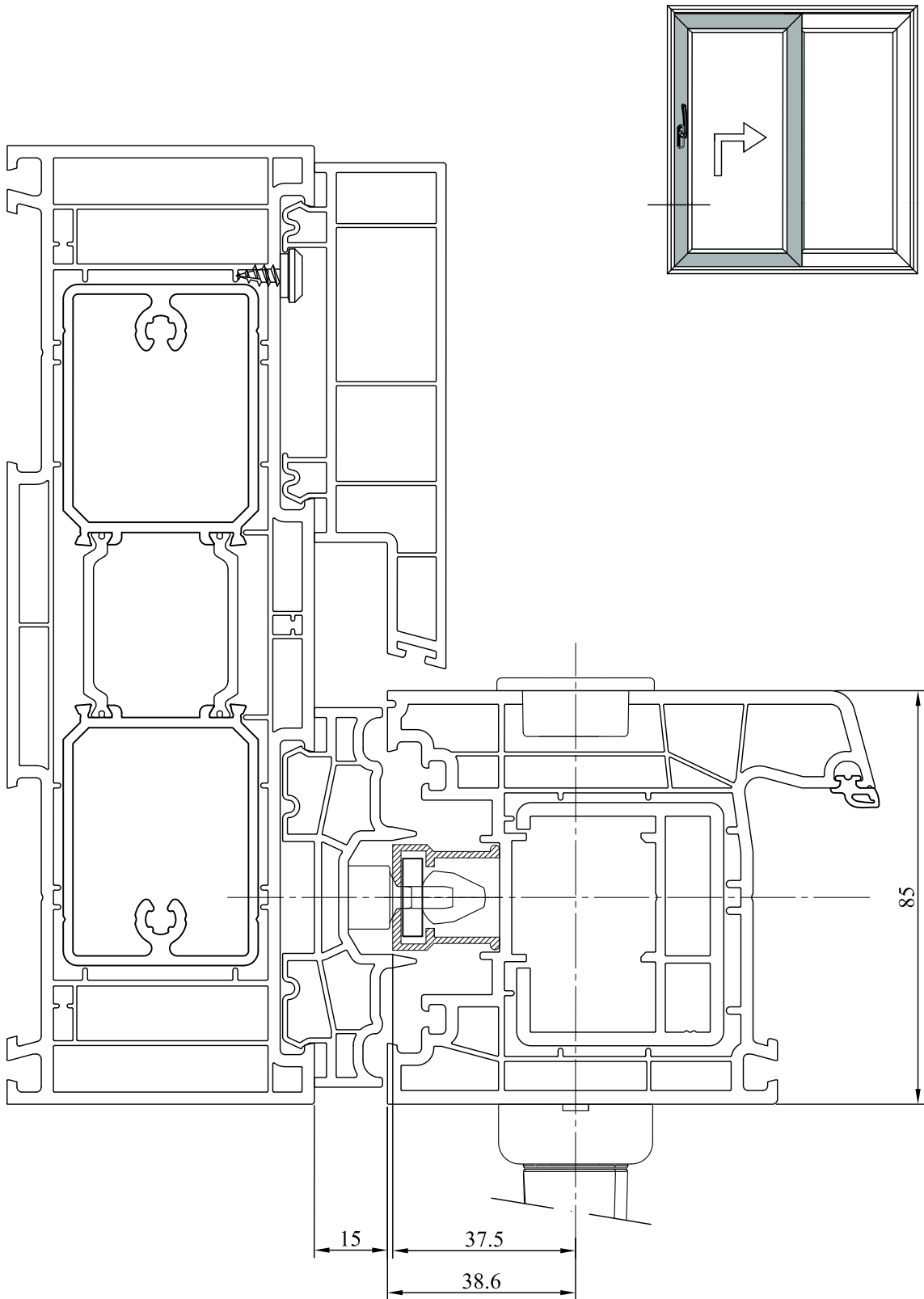

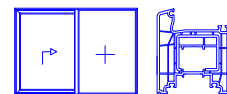

Aluplast 85

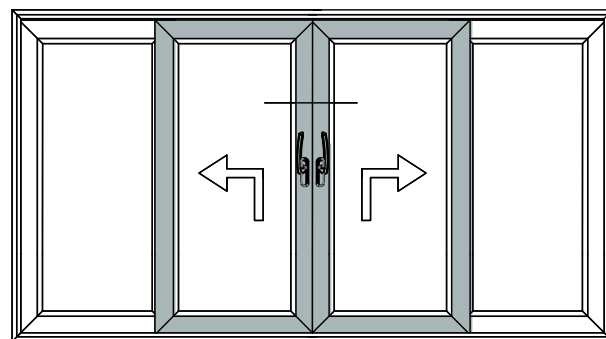
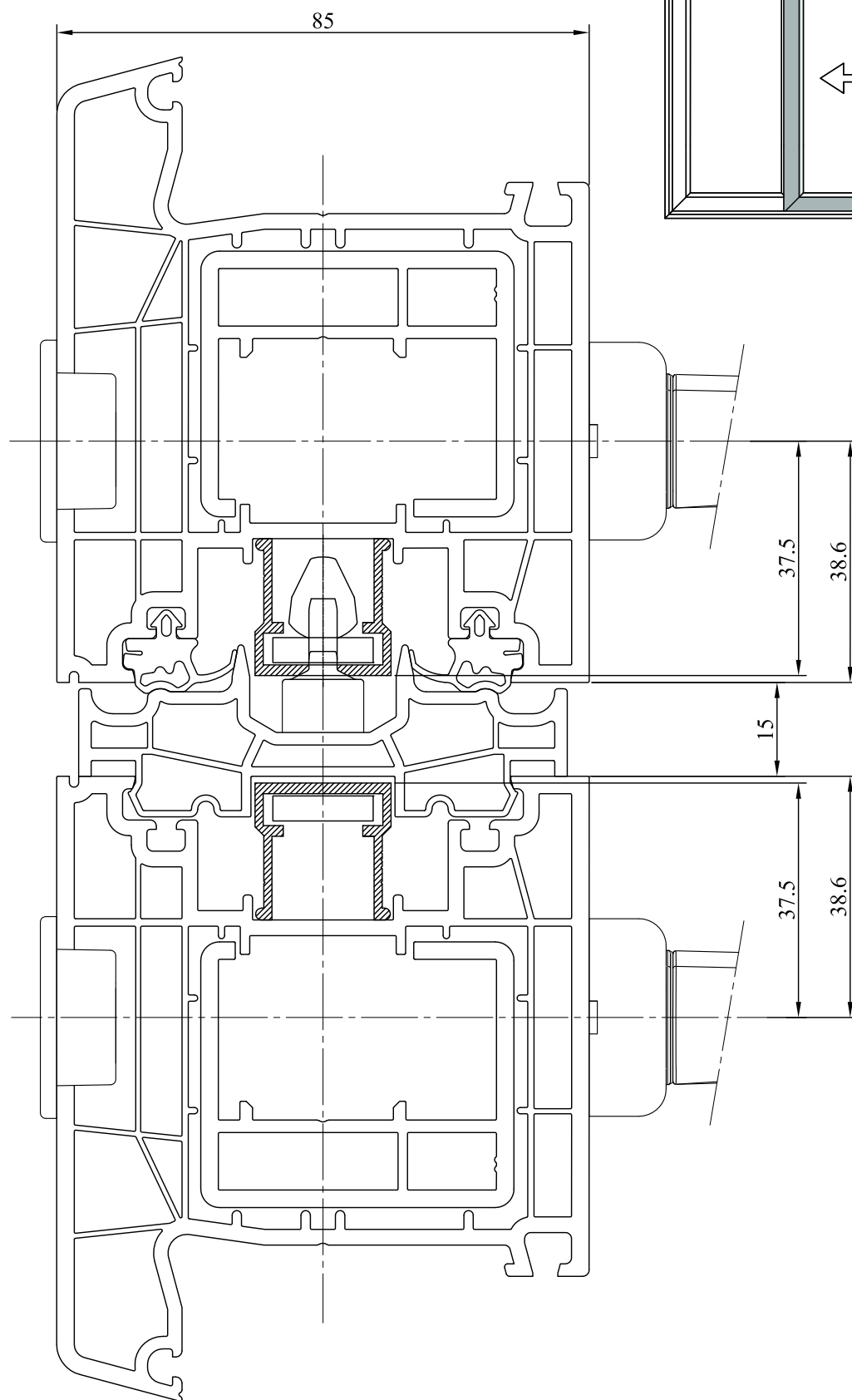

KLIZNO PODIZNI SISTEM

LIFT AND SLIDE

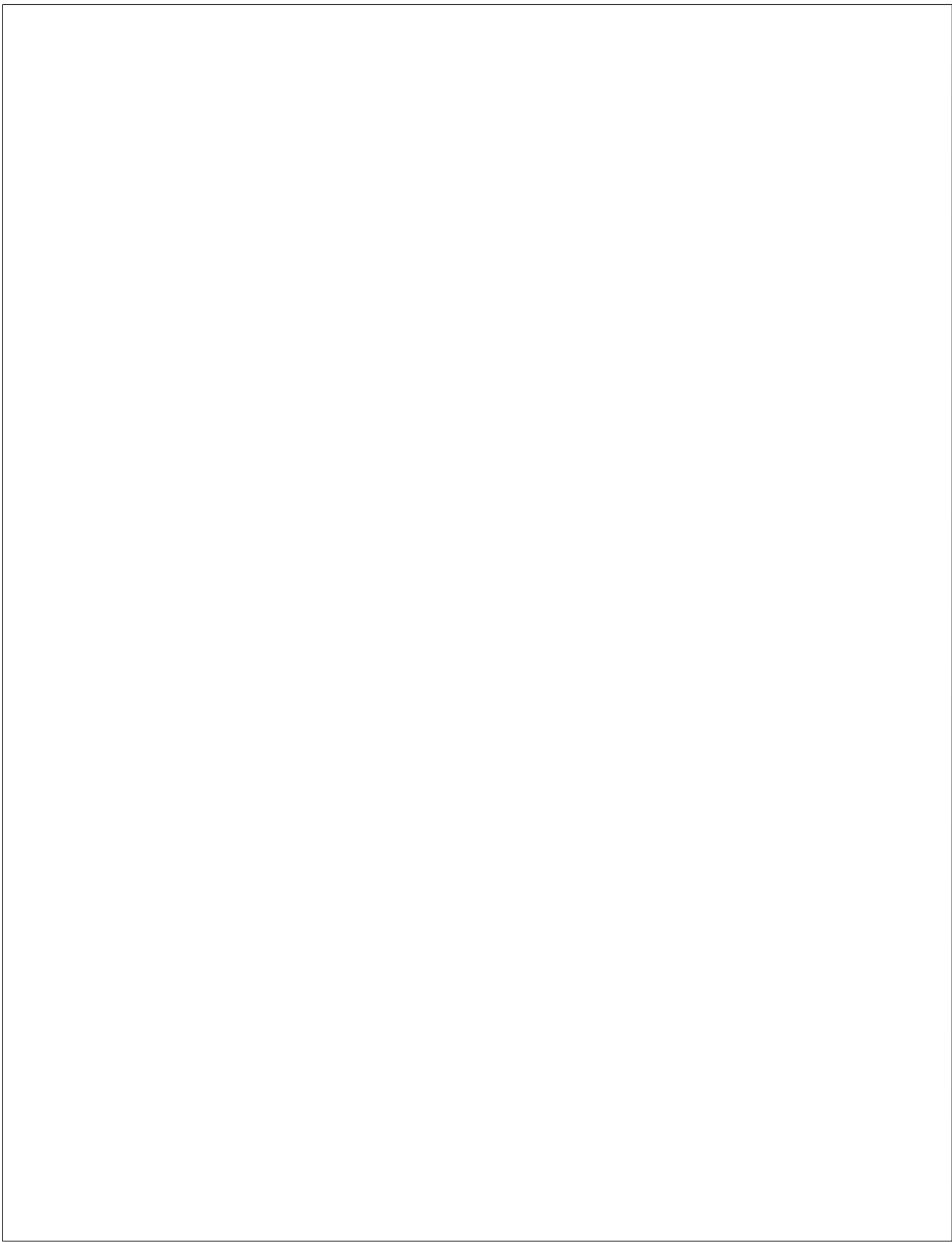

*Klizno podizni sistem za
Aluminijum 150kg*

*Lift and slide system for
Aluminum 150kg*

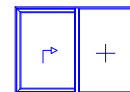

Elvial 6700

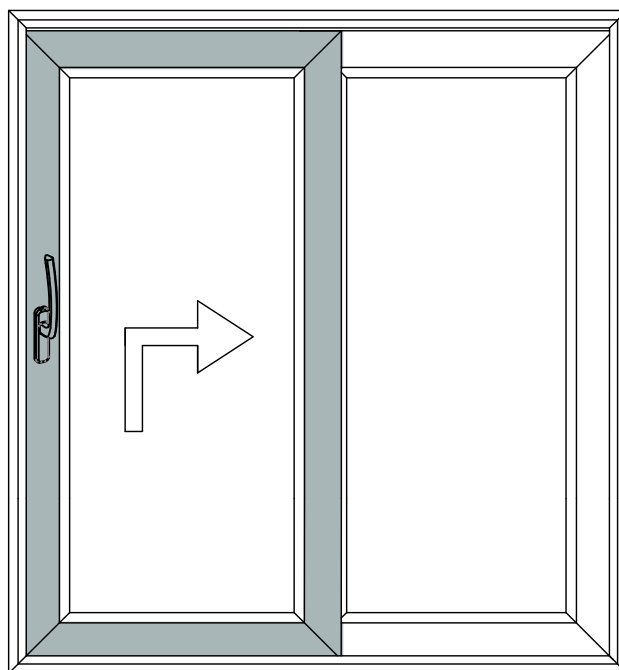
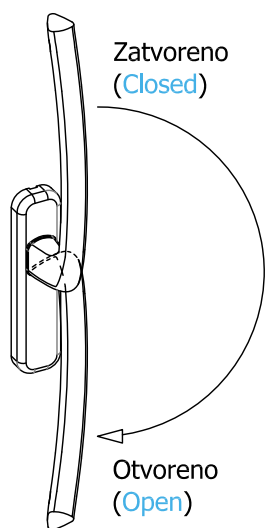

Sash arrangement

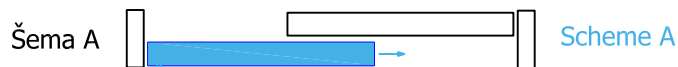

Tehnički podaci / Technical Data

Širina krila / Sash width 700 - 3250 mm
 Visina krila / Sash height 1150 - 2760 mm
 Spoljna širina okvira / Outer frame width 6500 mm

Nosivost krila / Sash weight max. 150 kg

Visina ručice / Handle position

Prozor / Window 408 mm

Vrata / Door 1008 mm

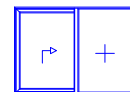

Elvial 6700

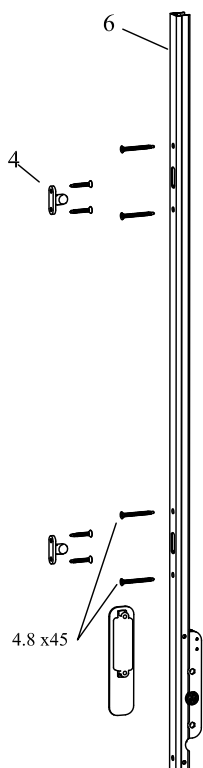

Klizno podizni sistem / Lift and slide system								
Poz. Pos.	Naziv elementa / Name	Šifra / Code	Šifra naručivanja / Order code	Šema / Scheme				
				A	D	C	F	
1	Prednja kolica / Front rollers	92010	set 94310	1	1	1	2	
2	Zadnja kolica / Back rollers	92016	set 94312		1		1	
3	Graničnik / Limiter	94020	set 94314			1		
4	Zabrlavljivač / Lock	92766	set 94316				1	
5	Spojka kolica / Rollers connector	DK / FB	Dužina spojke / Length rollers connector					
		700-1500	750	92305	92305			
		1501-1750	1000	92310	92310	1	2	2
		1751-2250	1500	92315	92315			4
		2251-2750	2000	92320	92320			
6	Profil brave / Door lock profil	VK / FH	Dužina brave / Length door lock					
		1150-1760	1700	92205	92205	1	2	
		1830-2260	2200	92245	92245		2	4
		2080-2760	2700	92285	92285			
7	Pomoćna kolica (za težine krila preko 150 kg) / Assistance rollers (for weight > 150 kg)	92660	92660					

Klizno podizni sistem / Lift and slide						
Poz. Pos.	Naziv elementa / Name	Šifra / Code	set 94310	set 94312	set 94314	set 94316
			Kom. Pes.	Kom. Pes.	Kom. Pes.	Kom. Pes.
1	Prednja kolica / Front rollers	92520	1	1	1	1
2	Zadnja kolica / Back rollers	92620	1	1	1	1
3	Graničnik / Limiter	94020	2	-	2	-
4	Zabrlavljivač / Lock	92766	3	3	-	-

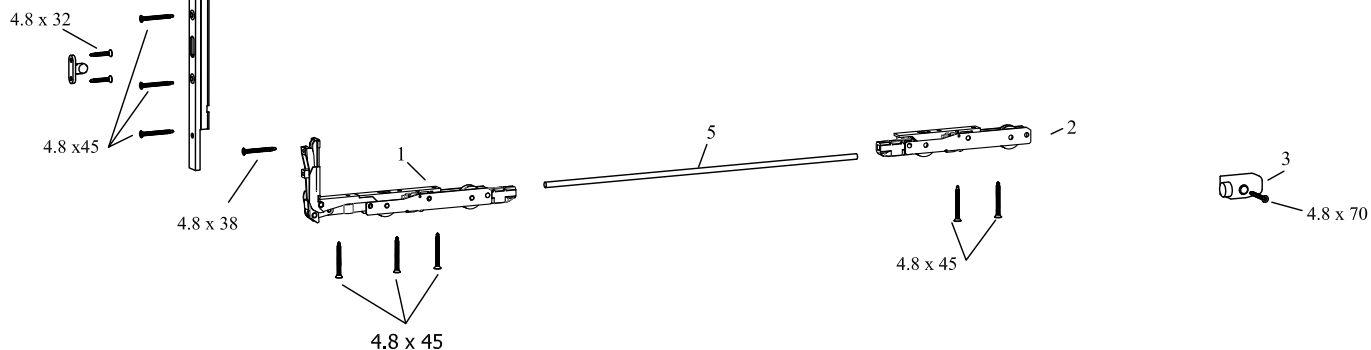

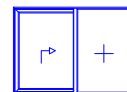

Elvial 6700

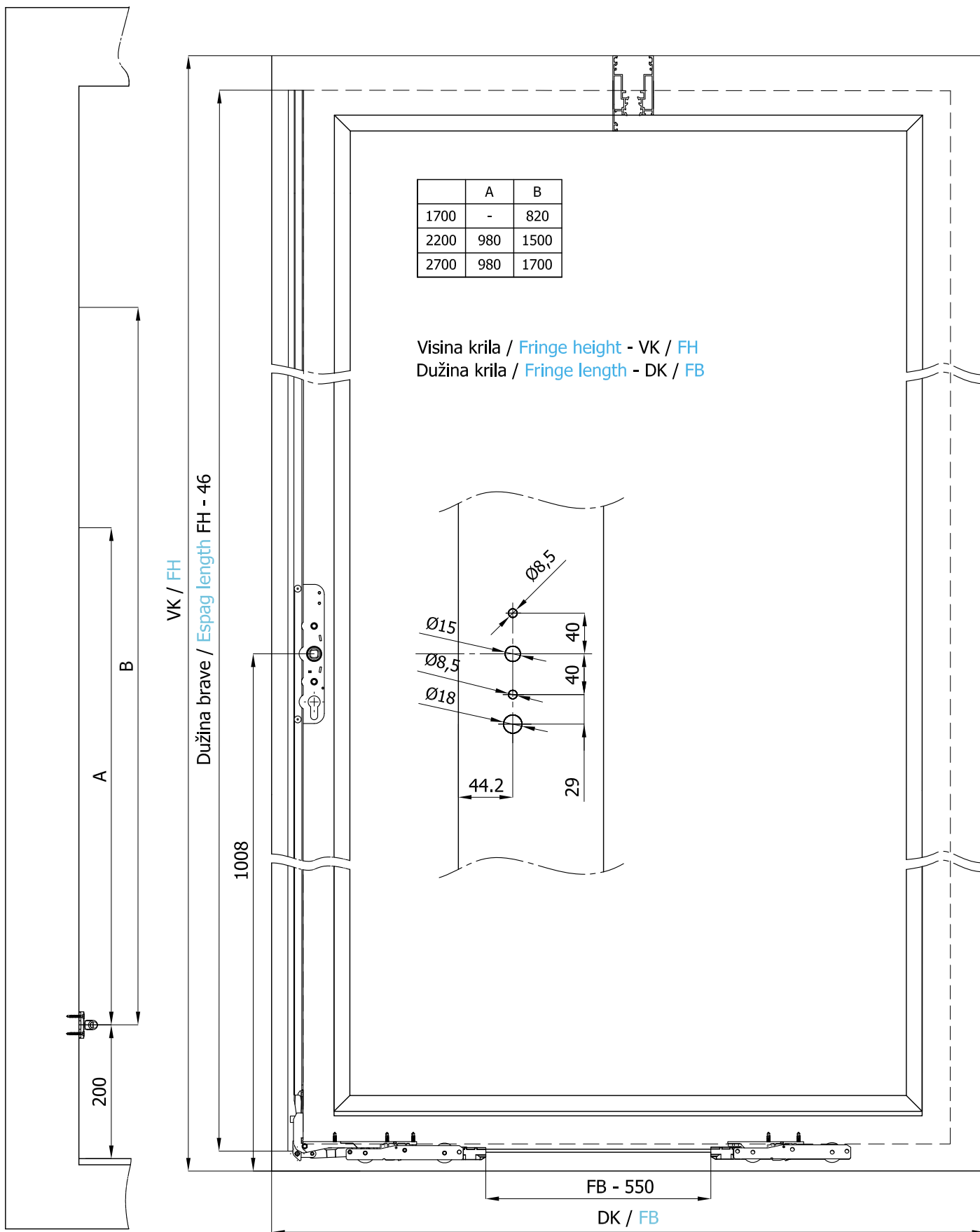

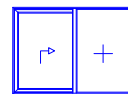

Elvial 6700

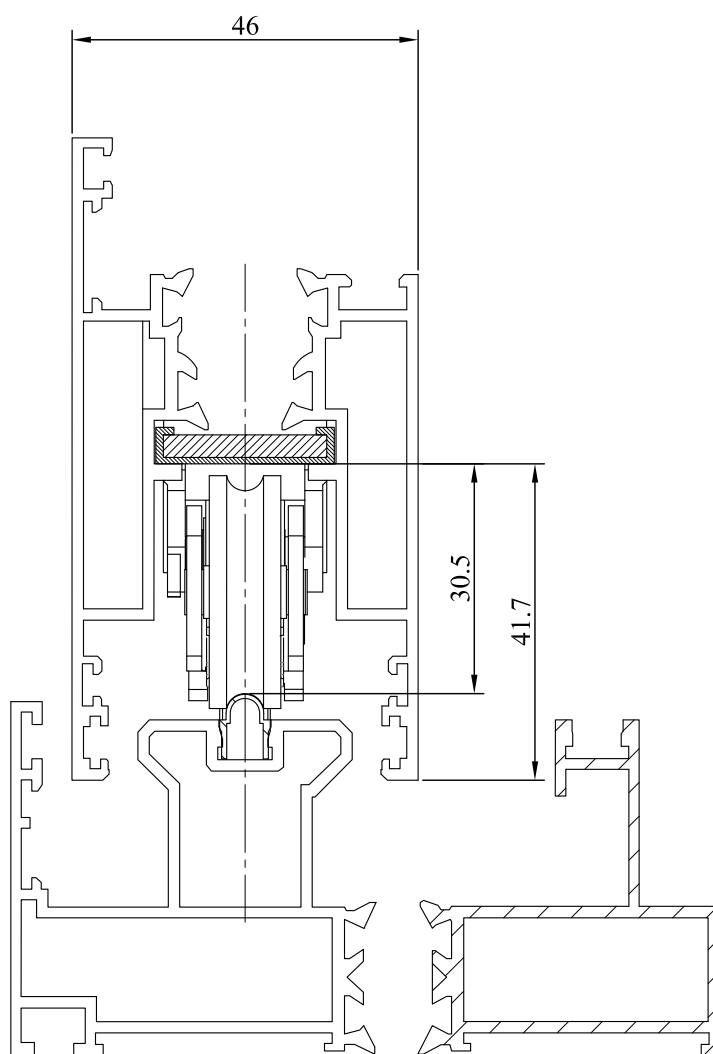
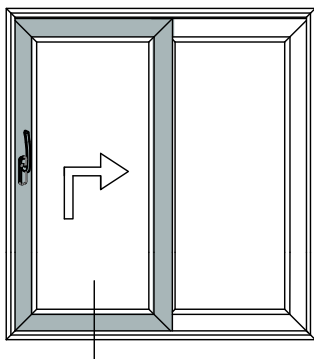

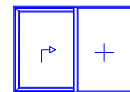

Elvial 6700

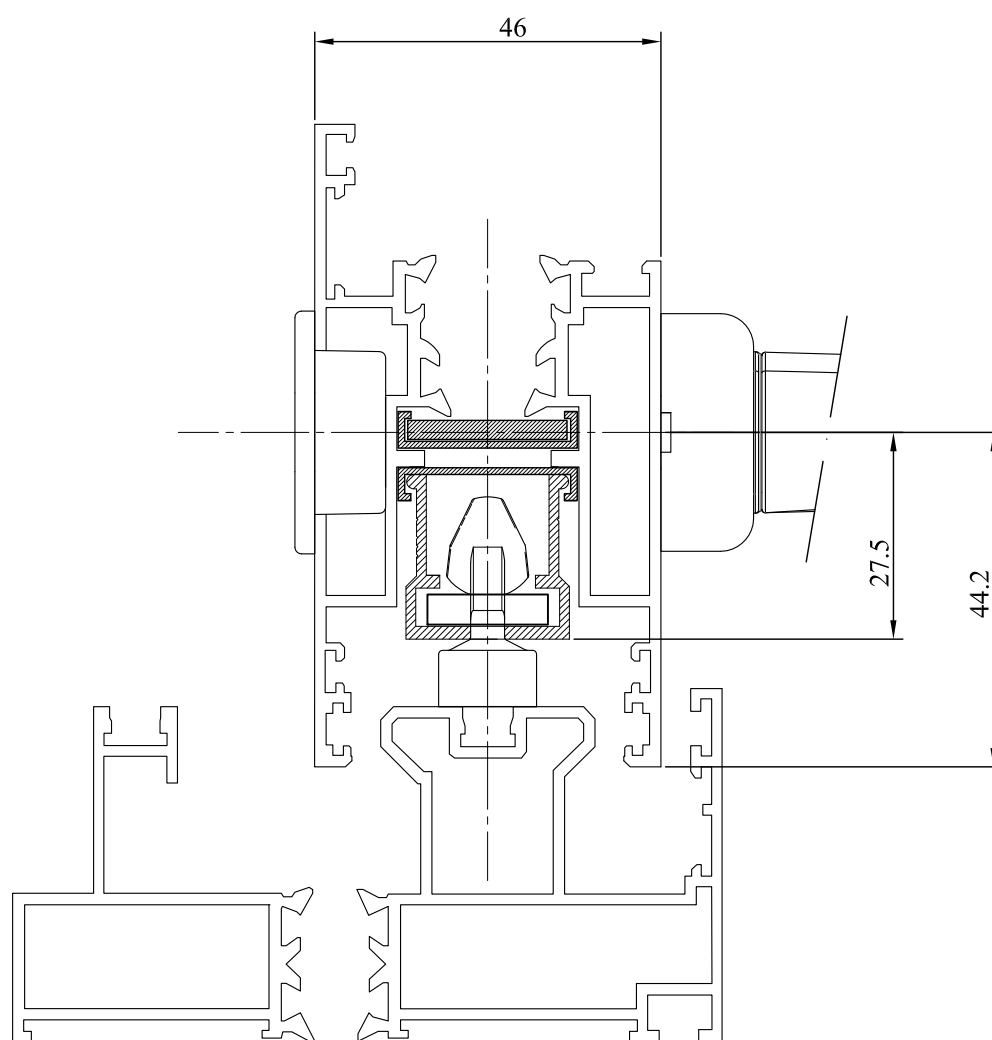
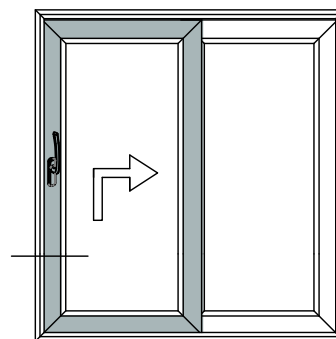

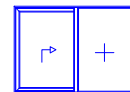

Elvial 6700

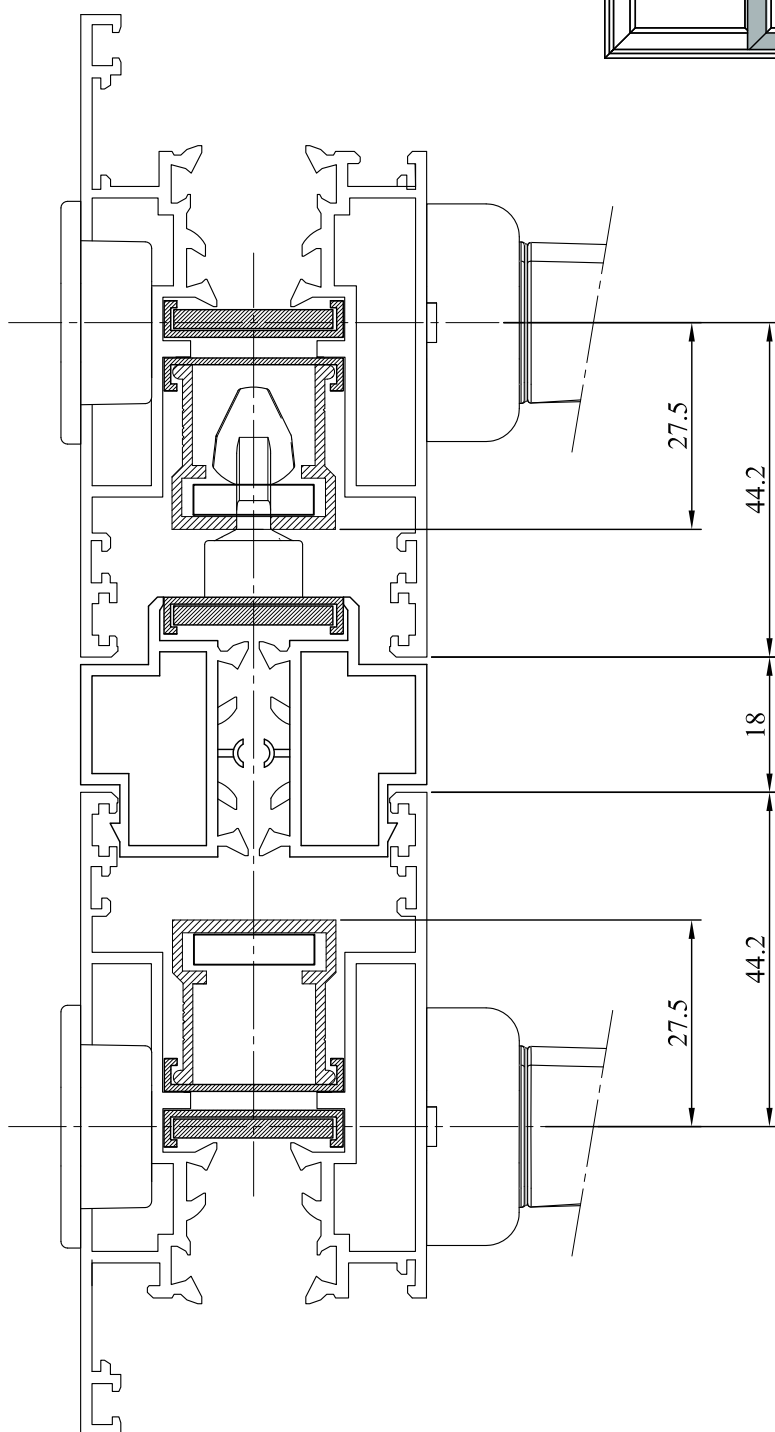
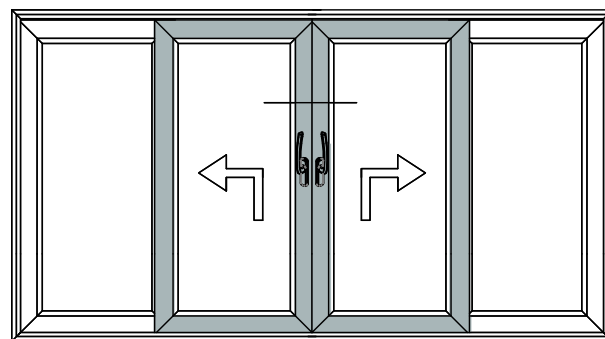

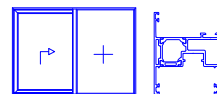

Schuco Ass 70

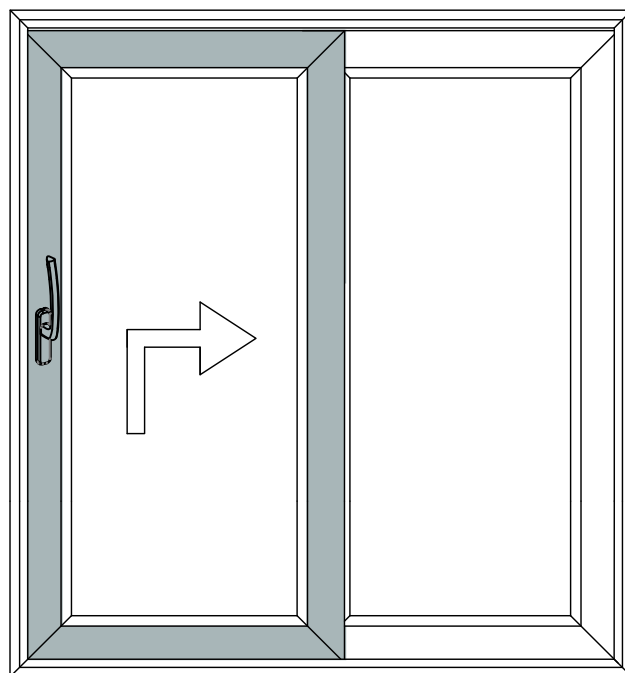
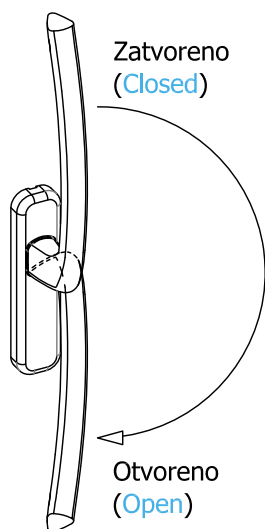

Sash arrangement

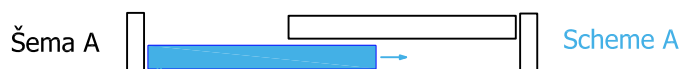

Tehnički podaci / Technical Data

Širina krila / Sash width	700 - 3250 mm
Visina krila / Sash height	1150 - 2760 mm
Spoljna širina okvira / Outer frame width	6500 mm

Nosivost krila / Sash weight max. 150 kg

Visina ručice / Handle position

Prozor / Window 409 mm

Vrata / Door 1009 mm

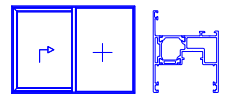

Schuco Ass 70

Klizno podizni sistem / Lift and slide system									
Poz. Pos.	Naziv elementa / Name	Šifra / Code	Šifra naručivanja / Order code	Šema / Scheme					
				A	D	C	F		
1	Prednja kolica / Front rollers	92010	set 94320	1	1	1	2		
2	Zadnja kolica / Back rollers	92016	set 94322		1		1		
3	Graničnik / Limiter	94020	set 94324			1			
4	Zabavljivač / Lock	92762	set 94326				1		
5	Spojka kolica / Rollers connector	DK / FB	Dužina spojke / Length rollers connector	1	2	2	4		
		700-1500	750					92305	92305
		1501-1750	1000					92310	92310
		1751-2250	1500					92315	92315
		2251-2750	2000					92320	92320
6	Profil brave / Door lock profil	VK / FH	Dužina brave / Length door lock	1	2	2	4		
		1150-1760	1700					92205	92205
		1830-2260	2200					92245	92245
		2080-2760	2700					92285	92285
7	Pomoćna kolica (za težine krila preko 150 kg) / Assistance rollers (for weight > 150 kg)	92660	92660						

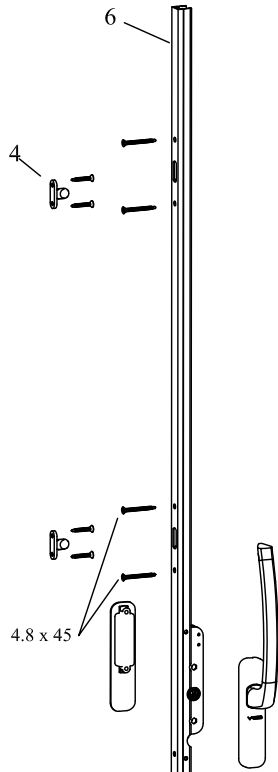

Klizno podizni sistem / Lift and slide							
Poz. Pos.	Naziv elementa / Name	Šifra / Code	set 94320	set 94322	set 94324	set 94326	
			Kom. Pes.	Kom. Pes.	Kom. Pes.	Kom. Pes.	
1	Prednja kolica / Front rollers	92520	1	1	1	1	
2	Zadnja kolica / Back rollers	92620	1	1	1	1	
3	Graničnik / Limiter	94020	2	-	2	-	
4	Zabavljivač / Lock	92762	3	3	-	-	

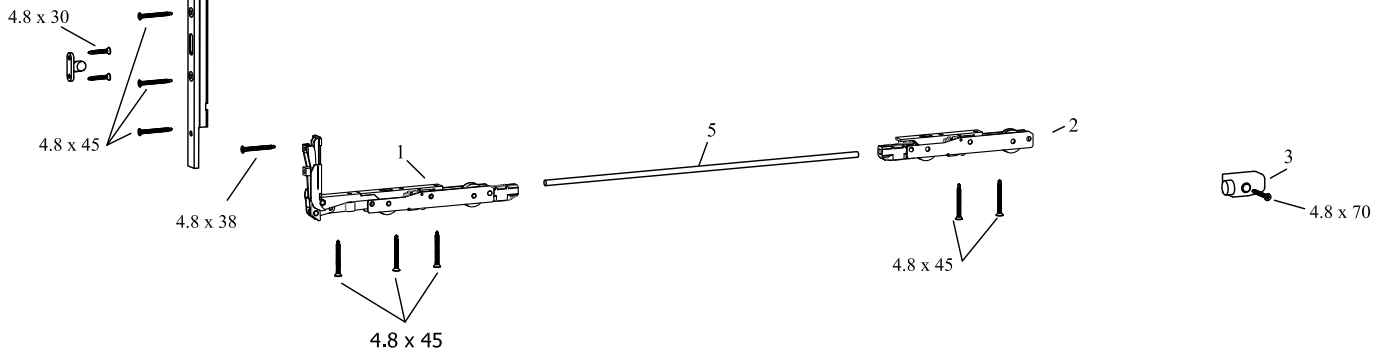

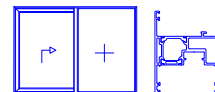

Schuco Ass 70

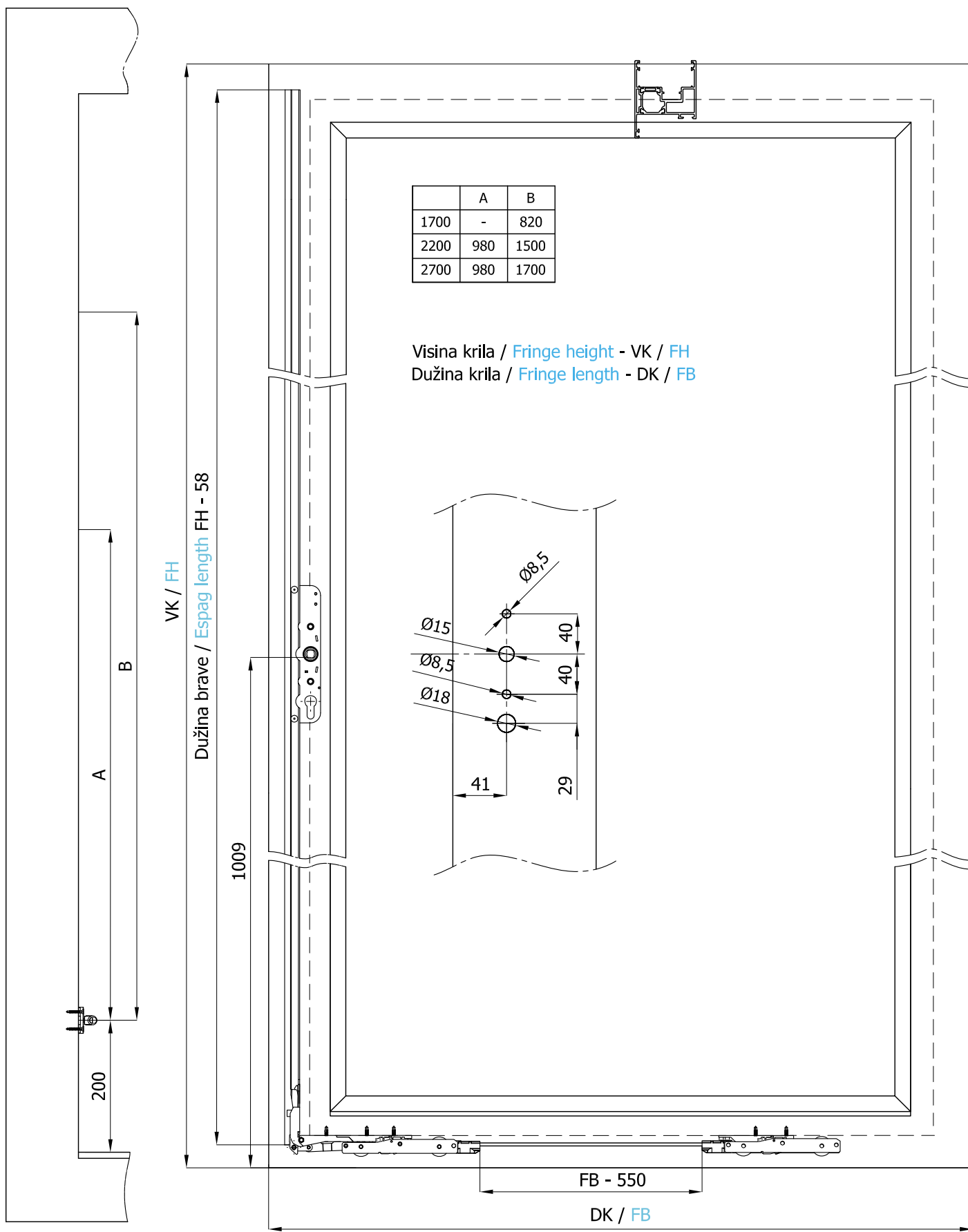

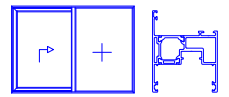

Schuco Ass 70

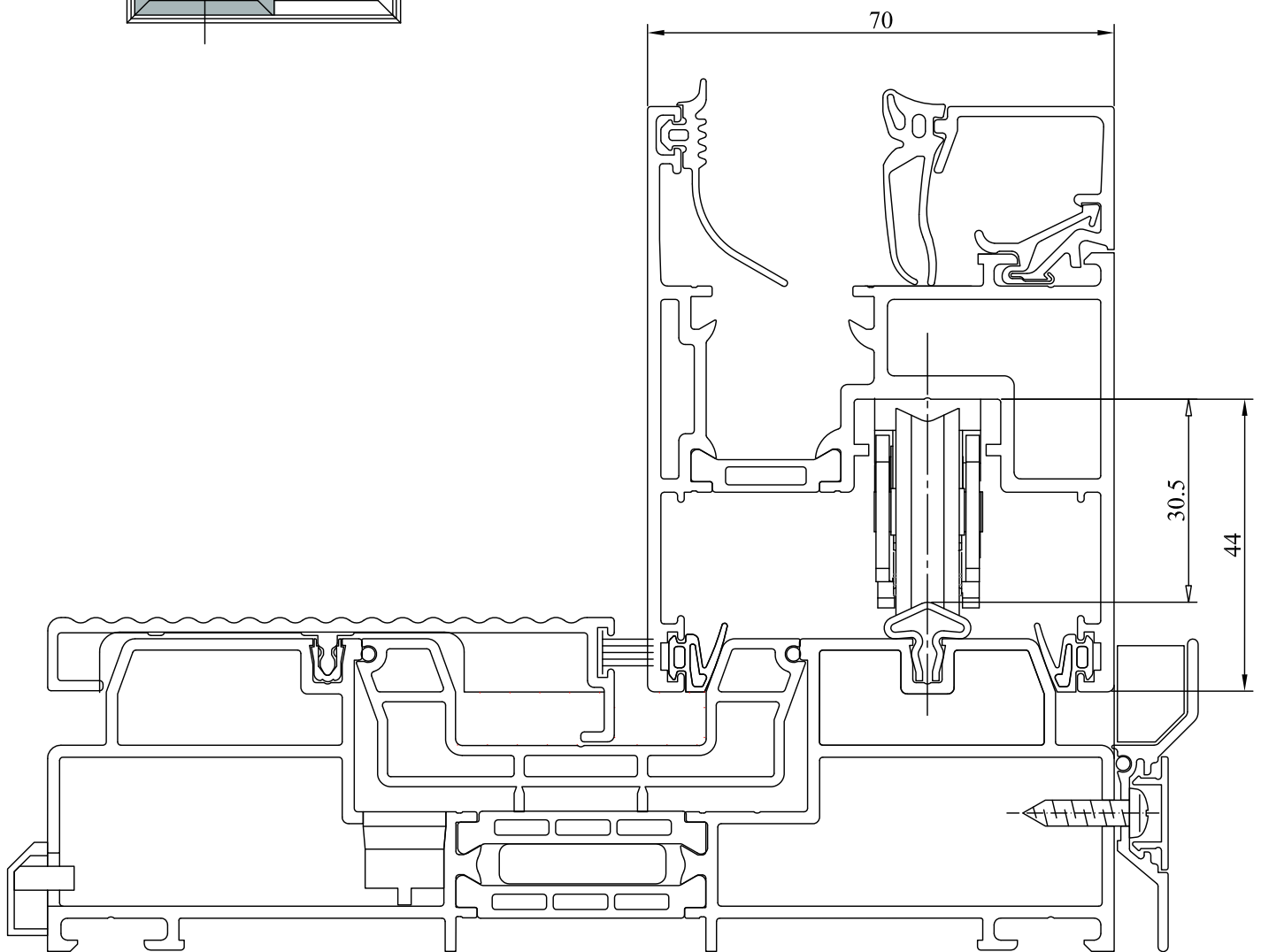
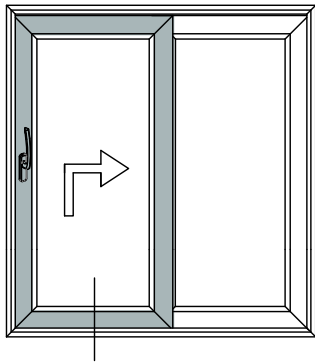

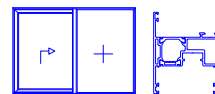

Schuco Ass 70

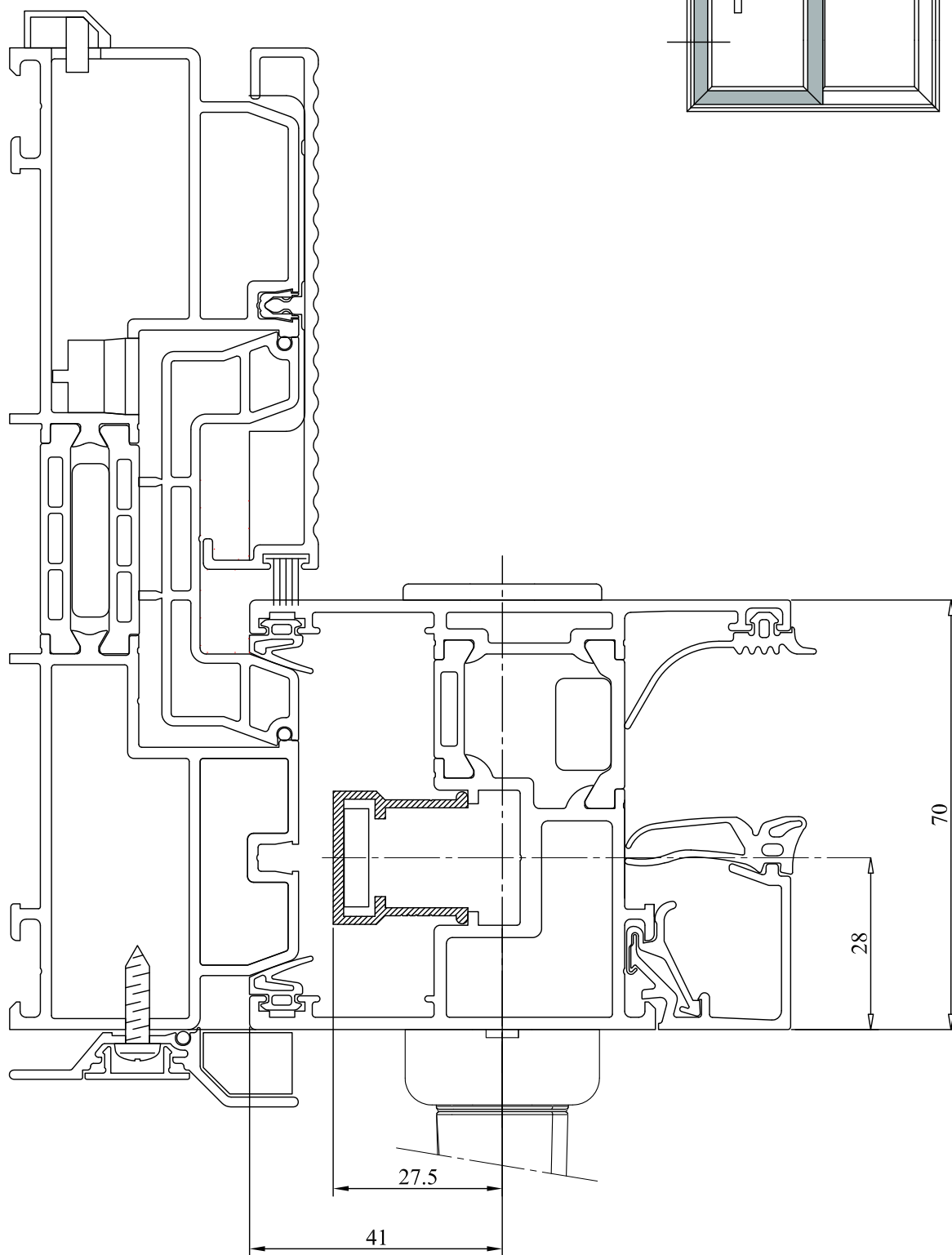
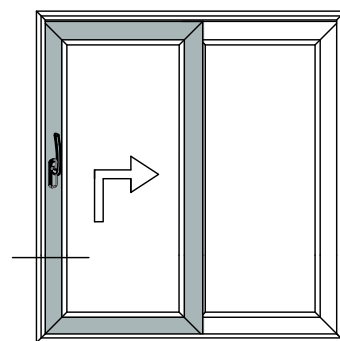

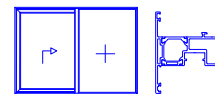

Schuco Ass 70

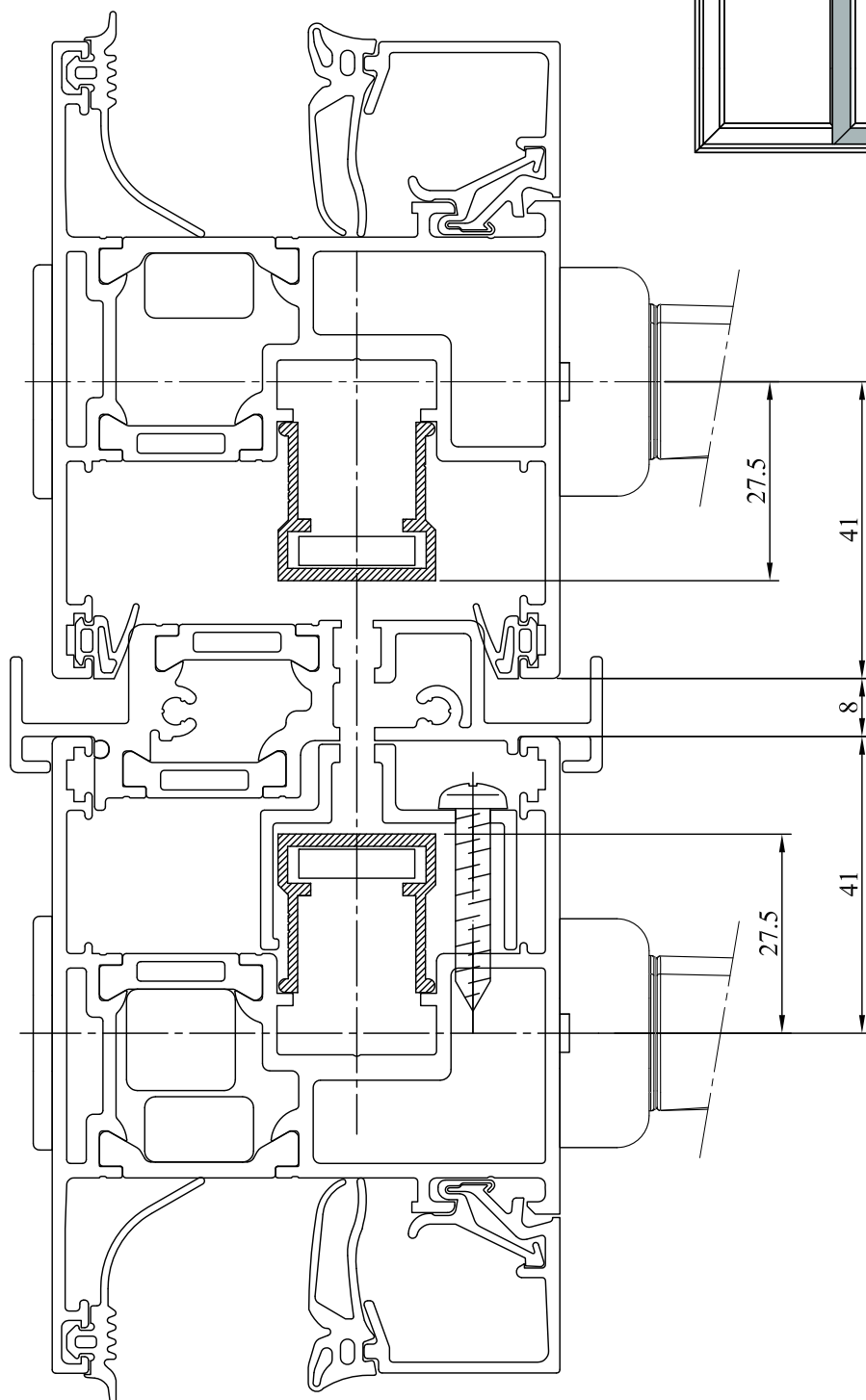
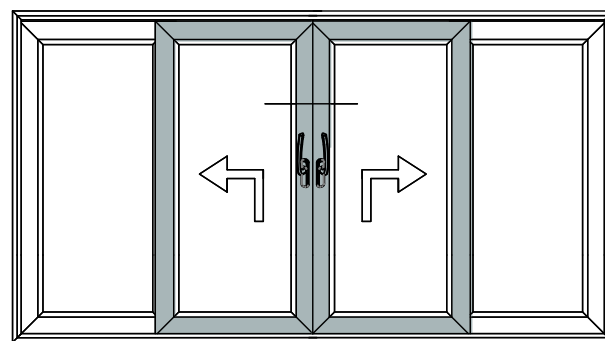

KLIZNO PODIZNI SISTEM

LIFT AND SLIDE

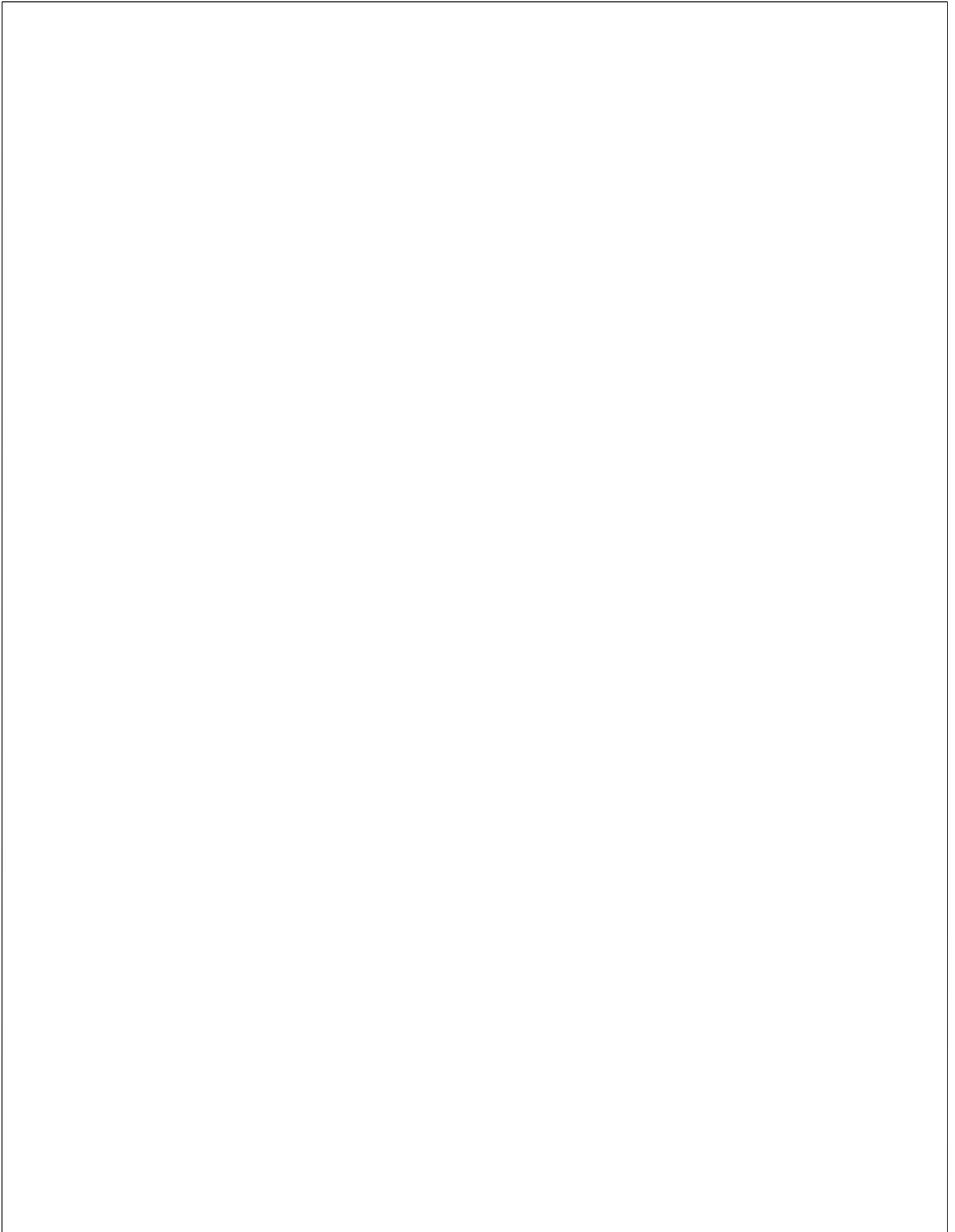

Ručice za klizno podizni sistem

Door handle for lift and slide

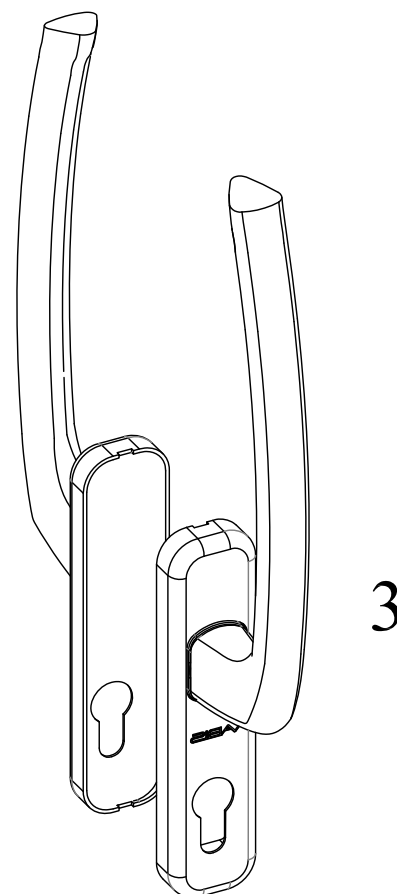
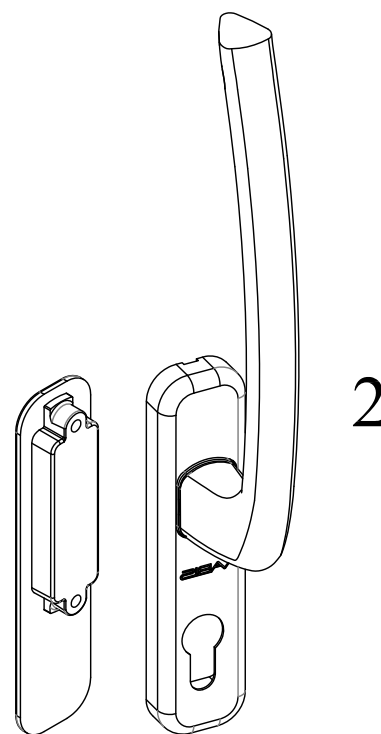
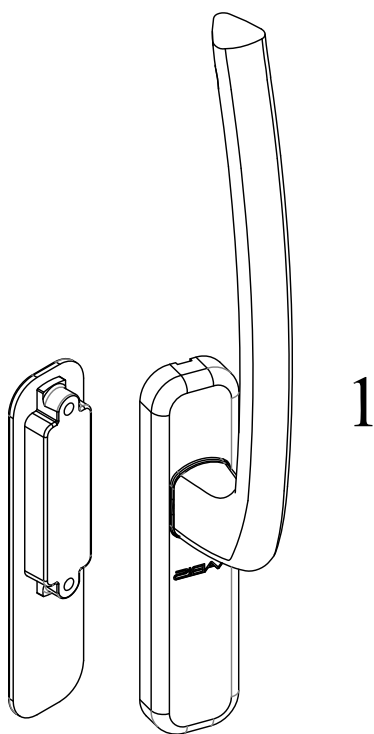
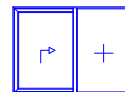

Klizno podizni sistem / Lift and slide		
Poz. / Pos.	Naziv elementa / Name	Šifra / Code
1	Ručica sa spoljnim povlakačem bela / Handle with external lug white	80650-1
2	Ručica sa spoljnim povlakačem braon / Handle with external lug braon	80650-2
3	Ručica sa spoljnim povlakačem siva / Handle with external lug gray	80650-3
4	Ručica sa spoljnim povlakačem crna / Handle with external lug black	80650-4
5	Ručica sa spoljnim povlakačem i umetkom za zaključavanje bela / Handle with external lug and insert lock white	80655-1
6	Ručica sa spoljnim povlakačem i umetkom za zaključavanje braon / Handle with external lug and insert lock braon	80655-2
7	Ručica sa spoljnim povlakačem i umetkom za zaključavanje siva / Handle with external lug and insert lock gray	80655-3
8	Ručica sa spoljnim povlakačem i umetkom za zaključavanje crna / Handle with external lug and insert lock black	80655-4
9	Ručica sa umetkom za zaključavanje bela / Handle with insert lock white	80660-1
10	Ručica sa umetkom za zaključavanje braon / Handle with insert lock braon	80660-2
11	Ručica sa umetkom za zaključavanje siva / Handle with insert lock gray	80660-3
12	Ručica sa umetkom za zaključavanje crna / Handle with insert lock black	80660-4

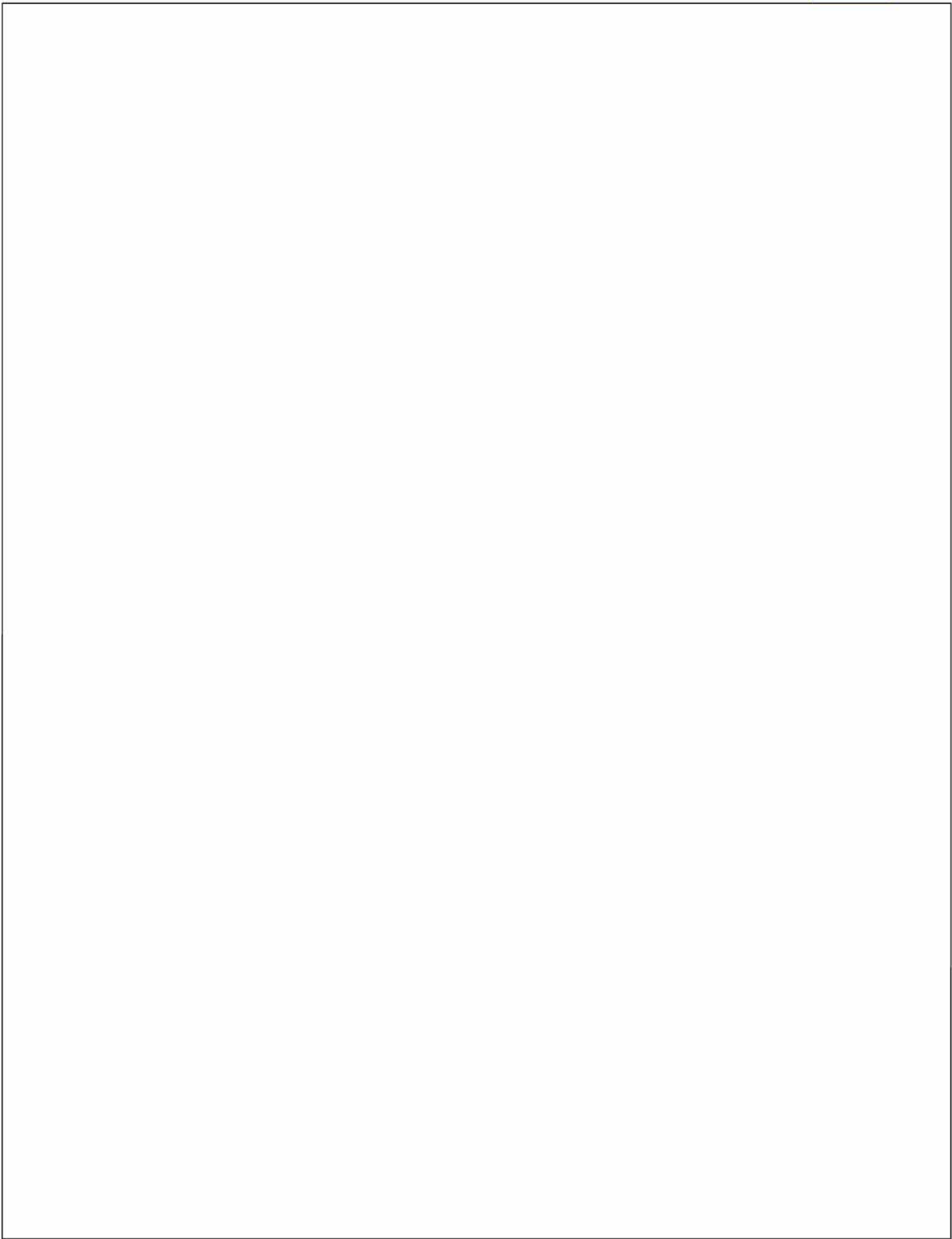
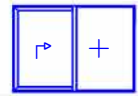

Iz Srbije u
From Serbia to
Из Србији в

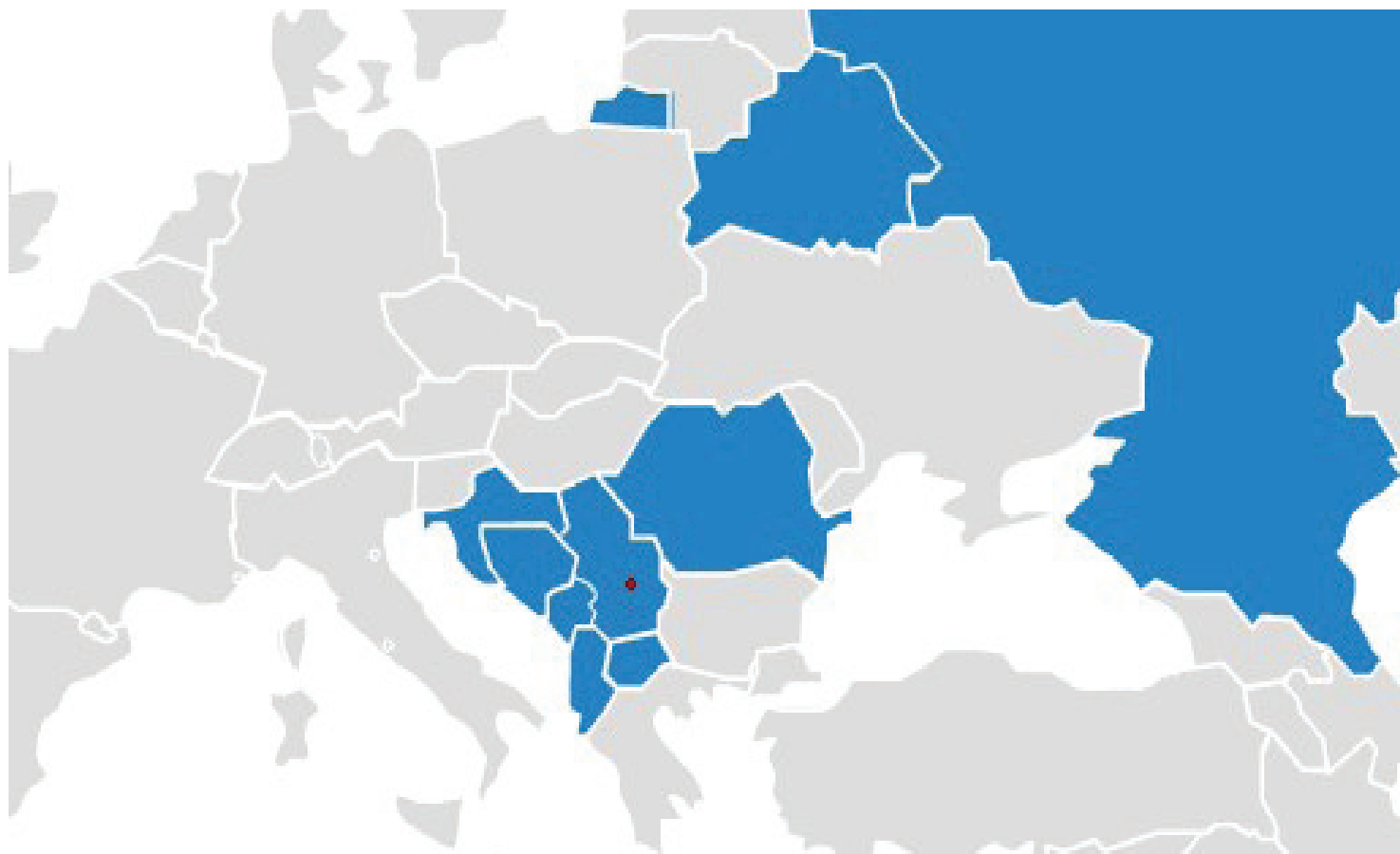

- Rusiju
- Belorusiju
- Rumuniju
- Albaniju
- Makedoniju
- Crnu Goru
- Hrvatsku
- Bosnu i Hercegovinu
- Sloveniju

Uslovi prodaje, slanja i plaćanja

Osnovne odgovornosti

Za naše isporuke važe isključivo naši uslovi prodaje, isporuke i plaćanja. Kupac ima prvo da ne ispoštuje ili ograniči neki propis samo ako mi to njemu pismenim putem potvrdimo. U okviru tekuće prodaje važe sledeći propisi i uslovi i važiće i onda kada se posebno ne ugovaraju.

Ponuda, naručivanje, kupoprodajni ugovor

Sve naše ponude su slobodne. Porudžbina se smatra pravnosnažnim kupoprodajnim ugovorom. Naručilac – kupac je odgovaran za svoju porudžbinu.

Tehničko tehnološke promene na proizvodima

Neprestano usavršavanje Vabis-ovih proizvoda i težnja ka višem nivou kvaliteta je osnovni zadatak Vabis-a i to nam daje za pravo da promenimo pojedine detalje. Promene ne moraju biti najavljene.

Cene

Naše cene su navedene u cenovnicima i važe u navedenim valutama, netto bez PDV-a, ali za svaku firmu, odnosno kupca zasebno i mogu se međusobno razlikovati.

Isporučena količina

I najmanja količina robe za isporuku se tretira isto i pakuje se regularno, osim ako je drugacije naznačeno u našem katalogu.

Vreme isporuke

Isporuka kataloške robe se obavlja sa lagera i termini i vreme isporuke se poštuju pod uslovom da pogonski uslovi to dozvoljavaju

Isporuka, garancija, reklamacija

Mi dajemo garanciju za naše proizvode. Sve reklamacije se moraju poslati najkasnije u roku od 10 dana nakon prijema robe. Kupac je dužan da nam odobri naknadnu isporuku, jer u suprotnom smo oslobođeni te obaveze. Ovo takođe važi ukoliko nam kupac ne stavi na raspolaganje reklamiranu robu. Neproisni pokušaji popravke i spolja vidljive promene kao i neodgovarajuće rukovanje dovode do trenutnog poništenja garancije, a dalji zahtevi za garanciju su isključeni.

Dajemo garanciju od 5 godina na funkcionalnost svojih proizvoda, pod uslovom da se kupac pridržavao datih uputstva za ugradnju i eksploataciju (propisani način ugradnje dat u katalogu, podmazivanje okova jednom godišnje i neizlaganje okova štetnim hemijskim sredstvima). Garancija ne važi u slučaju bilo kog spoljnog nepredviđenog mehaničkog ili hemijskog delovanja na proizvod. Kupac je dužan da reklamaciju obrazloži, dokumentuje validnim dokazima (fotografija, izjava strucnog lica i sl.). Nakon podnošenja zahteva za reklamaciju VABIS je u obavezi da u roku od 10 dana razmotri istu i u slučaju pozitivnog rešenja kupcu isporuči proizvode istog ranga. VABIS je u obavezi da o svom trošku pošalje nove proizvode na adresu kupca. Zamena proizvoda na terenu nije nadležnost VABIS-a.



D.O.O. VABIS, ul Tihomira Djordjevića bb, Aleksinac - www.vabis.co.rs - office@vabis.co.rs

Tel. +381 (0)18 804 007 , 800 009 Fax.+381 (0)18 800 008

GPS - N 43 33' 2,61" E - 21 41' 25,33"